

ELECRAFT® K3

HIGH-PERFORMANCE 160 – 6 METER TRANSCEIVER

K3EXREF FREQUENCY LOCK OPTION INSTALLATION AND OPERATION

Revision A, May 11, 2011

Copyright © 2011, Elecraft, Inc.

All Rights Reserved

Contents

Introduction.....	3
Customer Service and Support.....	3
Using the K3EXREF.....	4
Installing the K3EXREF	4
Anti Static Protection Required.....	4
Preparing for Installation.....	5
Tools Required	5
Firmware Required.....	5
Parts Included.....	5
Installation Procedure.....	6
Removing the K3Top Cover and Chassis Stiffener	6
Installing the TMP Cable	6
Installing the K3EXREF Board.....	9
Reassembly	10



Elecraft manuals with color images may be downloaded from
www.elecraft.com.

Introduction

The K3EXREF option locks the K3's reference oscillator frequency to an external 10 MHz source by automatically controlling the *REF CAL* function. While locked to the external source, the K3's reference oscillator frequency is maintained within 2 Hz. Since the K3EXREF does not phase lock the K3's reference oscillator, the external 10 MHz source has no impact on the K3's phase noise performance. For best performance we recommend your K3 be equipped with the KTCXO3-1 high stability (0.5 ppm typ.) reference oscillator.

The option consists of one small pc board that mounts on the existing KREF3 board and a cable assembly that brings in the external 10 MHz signal to the board from the K3's rear panel. No soldering is required to install the K3EXREF option.

Customer Service and Support

Technical Assistance

You can send e-mail to k3support@elecraft.com and we will respond quickly - typically the same day Monday through Friday. Telephone assistance is available from 9 A.M. to 5 P.M. Pacific time (weekdays only) at 831-763-4211. Please use e-mail rather than calling when possible since this gives us a written record of the details of your problem and allows us to handle a larger number of requests each day.

Repair / Alignment Service (We want to make sure everyone succeeds!)

If necessary, you may return your Elecraft product to us for repair or alignment. (Note: We offer unlimited email and phone support to get your kit running, so please try that route first as we can usually help you find the problem quickly.)

IMPORTANT: You must contact Elecraft before mailing your product to obtain authorization for the return, what address to ship it to and current information on repair fees and turnaround times. (Frequently we can determine the cause of your problem and save you the trouble of shipping it back to us.) Our repair location is different from our factory location in Aptos. We will give you the address to ship your kit to at the time of repair authorization. *Packages shipped to Aptos without authorization will incur an additional shipping charge for reshipment from Aptos to our repair depot.*

Elecraft's 1-Year Limited Warranty

This warranty is effective as of the date of first consumer purchase (or if shipped from factory, date product is shipped to customer). It covers both our kits and fully assembled products. For kits, before requesting warranty service, you should fully complete the assembly, carefully following all instructions in the manual.

Who is covered: This warranty covers the original owner of the Elecraft product as disclosed to Elecraft at the time of order. Elecraft products transferred by the purchaser to a third party, either by sale, gift or other method, who is not disclosed to Elecraft at the time of original order, are not covered by this warranty. If the Elecraft product is being bought indirectly for a third party, the third party's name and address must be provided to Elecraft at time of order to insure warranty coverage.

What is covered: During the first year after date of purchase, Elecraft will replace defective or missing parts free of charge (post-paid). We will also correct any malfunction to kits or assembled units caused by defective parts and materials. Purchaser pays inbound shipping to Elecraft for warranty repair, Elecraft will pay shipping to return the repaired equipment to you by UPS ground service or equivalent to the continental USA and Canada. Alaska, Hawaii and outside U.S. and Canada actual return shipping cost paid by owner.

What is not covered: This warranty does not cover correction of kit assembly errors. It also does not cover misalignment; repair of damage caused by misuse, negligence, or builder modifications; or any performance malfunctions involving non-Elecraft accessory equipment. The use of acid-core solder, water-soluble flux solder, or any corrosive or conductive flux or solvent will void this warranty in its entirety. Also not covered is reimbursement for loss of use, inconvenience, customer assembly or alignment time, or cost of unauthorized service.

Limitation of incidental or consequential damages: This warranty does not extend to non-Elecraft equipment or components used in conjunction with our products. Any such repair or replacement is the responsibility of the customer. Elecraft will not be liable for any special, indirect, incidental or consequential damages, including but not limited to any loss of business or profits.

Using the K3EXREF

If you are installing the K3EXREF yourself, go directly to *Installing the K3EXREF* below.

The operation of the K3EXREF is automatic, once a suitable signal is applied to the K3's rear-panel REF. connector. To confirm the external reference controls the K3 reference oscillator:

- Turn the K3 on. Confirm that TECH mode is on (*CONFIG:TECH MD On*).
- Monitor the K3's reference oscillator frequency (*CONFIG:REF CAL*)
- Connect the external 10 MHz signal source to the K3 rear panel REF. connector. The 10 MHz source should have a signal level between +4 dBm and +16 dBm, nominal. For square wave sources, 2VDC to 3.3VDC peak is optimum. If the source is a 5V logic level, use a 50-ohm resistor in series with the input. **Caution: To avoid damage to the K3EXREF, do not exceed these levels.**
- An asterisk symbol will appear (*REF*CAL*) will appear after several seconds indicating the K3's reference oscillator is now controlled by the external 10 MHz source. The * will blink on and off as long as a 10 MHz signal is being received.
- Manual control of *REF*CAL* is now disabled. *LOCKED* will appear if you try to adjust the VFO A knob. It will remain locked to avoid sudden jumps in frequency if the 10 MHz source is accidentally lost. If the 10 MHz source is removed, the * will stop blinking and the K3 will maintain the last reference oscillator frequency. To regain local control, remove the external source and cycle the K3's power off, then on again.

NOTE: If you want to maintain the calibration provided by the external 10 MHz source even when the 10 MHz source is not used, note the *REF*CAL* frequency and then, after disconnecting the external source and regaining local control by cycling the K3's power, manually set *REF CAL* to that frequency.

Installing the K3EXREF

Anti Static Protection Required

We strongly recommend you take the following anti-static precautions (listed in order of importance) to avoid ESD (Electro Static Discharge) damage:

- Leave ESD-sensitive parts in their anti-static packaging until you install them. The packaging may be a special plastic bag or the component's leads may be inserted in conductive foam. Parts which are especially ESD-sensitive are identified in the parts list and in the assembly procedures.
- Wear a conductive wrist strap with a series 1-megohm resistor. If you do not have a wrist strap, touch a bare metal ground briefly before touching any sensitive parts to discharge your body. Do this frequently while you are working. You can collect a destructive static charge on your body just sitting at the work bench.

WARNING

DO NOT attach a ground directly to yourself without a current-limiting resistor as this poses a serious shock hazard. A wrist strap must include a 1-megohm resistor to limit the current flow. If you choose to touch an unpainted, metal ground to discharge yourself, do it only when you are not touching any live circuits with your other hand or any part of your body.

- Use a grounded anti-static mat on your work bench.
- No soldering is required but if you choose to use a soldering iron for any reason, be sure your iron has an ESD-safe grounded tip tied to the same common ground used by your mat or wrist strap.

Preparing for Installation

Tools Required

1. #0 and #1 size Phillips screwdrivers. To avoid damaging screws and nuts, a power screwdriver is *not* recommended. Use the screwdriver that best fits the screw in each step.
2. Soft cloth or clean, soft static dissipating pad to lay cabinet panels on to avoid scratching.
3. Long (needle) nose pliers.
4. Second pair of pliers or a 5/16" nut driver to tighten the SMA connector nut.

The following tools are strongly recommended:









1. ESD wrist strap.
2. Static dissipating work pad.

Firmware Required

The K3EXREF requires firmware version 4.28 or later installed in your K3. Your K3 Owner's manual has complete instructions for updating your firmware.

Parts Included

The following parts should be included in your kit. Check to ensure you have them all. If any parts are damaged or missing, contact Elecraft for replacements (see *Customer Service and Support*, page 3).

ILLUSTRATION	DESCRIPTION	QTY.	ELECRAFT PART NO.
	K3EXREF Circuit Board	1	E850445
	Header Shorting Block, 2-pin (May be already installed on the K3EXREF circuit board, J1, see Figure 8 on pg 9).	1	E620055
	Screw, Pan Head, 5/8" (15.9 mm)	1	E700114
	Lock Washer, 4, Split Ring	1	E700004
	Lock Washer, 4, Inside Tooth	1	E700010
	Spacer, 1/4" (6.4 mm).	1	E700220
	TMP Cable Assembly with Mounting Hardware (see Figure 3, pg 7).	1	E850446
	SMA-BNC Adapter, M-F	1	E620216

Installation Procedure

Removing the K3 Top Cover and Chassis Stiffener

- Disconnect power and all cables from your K3.
- Remove the nine screws to free the top cover as shown in Figure 1. After the cover is open, lift it gently to reach the speaker wire connector. Unplug the speaker then set the top cover aside in a safe place.

⚠ CAUTION: Whenever you remove screws from a panel, if one screw seems too tight to loosen without damaging it, first loosen the other screws then try again. Sometimes one screw binds in its hole when the other screws are tightened.

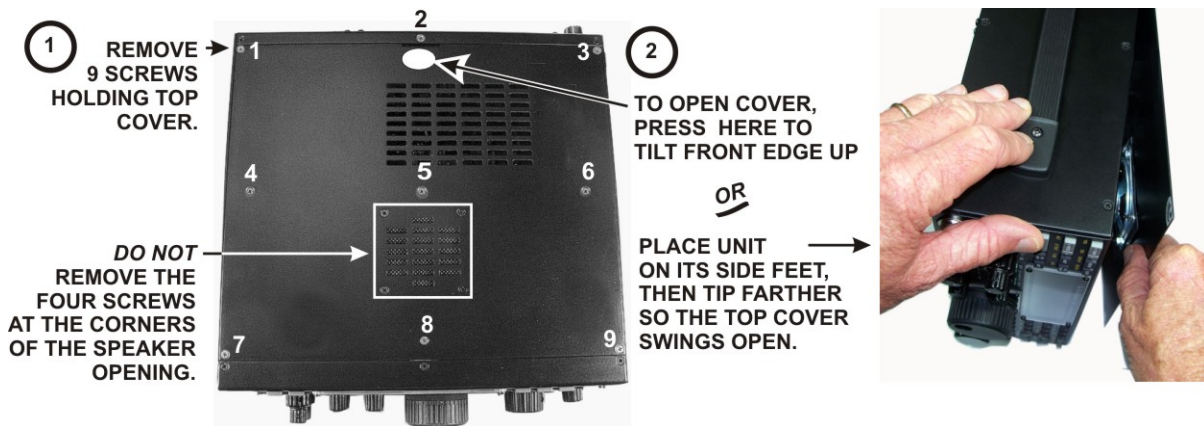

Figure 1. Removing K3 Top Cover.

⚠ CAUTION: Touch an unpainted metal ground or wear a grounded wrist strap before touching components or circuit boards inside the K3. See page 4 for more information.

- Remove the stiffener bar that runs from side to side across the top of the K3 chassis. This is the bar the three screws across the center of the top cover thread into. The bar is held in place by a single screw at each side and, if the KPA3 100 watt option is installed, by two screws attaching it to the KPA3 shield. Some KPA3 shields have PEM nuts permanently attached to the shield for the screws. Others use ordinary nuts that must be removed with the screws and lock washers.

Installing the TMP Cable

- If you have the K144XV 2-meter module installed, remove it as follows. Otherwise go to the next step with a square check box.

1. Unplug the single red wire power lead from the 12V connector on the K144XV module.
2. Remove the three 6-32 screws that secure the K144XV module to the left side panel as shown in Figure 2.

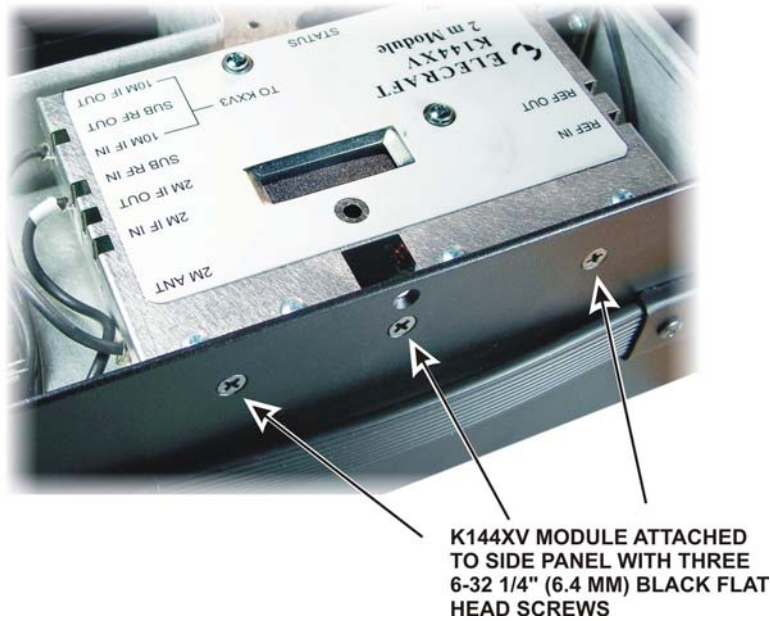

Figure 2. Freeing the K144XV Module.

3. Unplug the coaxial cables leading to the K144XV module and set the module aside. The coaxial cables have friction-fit TMP connectors that simply pull out of the sockets (see Figure 6 on pg 9). Pull on the metal connector grips. Do not pull on the coaxial cable. If needed use your needle-nose pliers to grasp the metal grips on the connectors.

- Remove the K3 left side panel (the side with the handle).
- Remove the plug from the REF. hole in the K3 rear panel (next to the KEY OUT connector). The plug has keys on either side to hold it in place. Squeeze each key to release it.
- Install the SMA connector in the REF. hole as shown in Figure 3. Note that the rubber grommet fits inside the rear panel hole to center the connector.

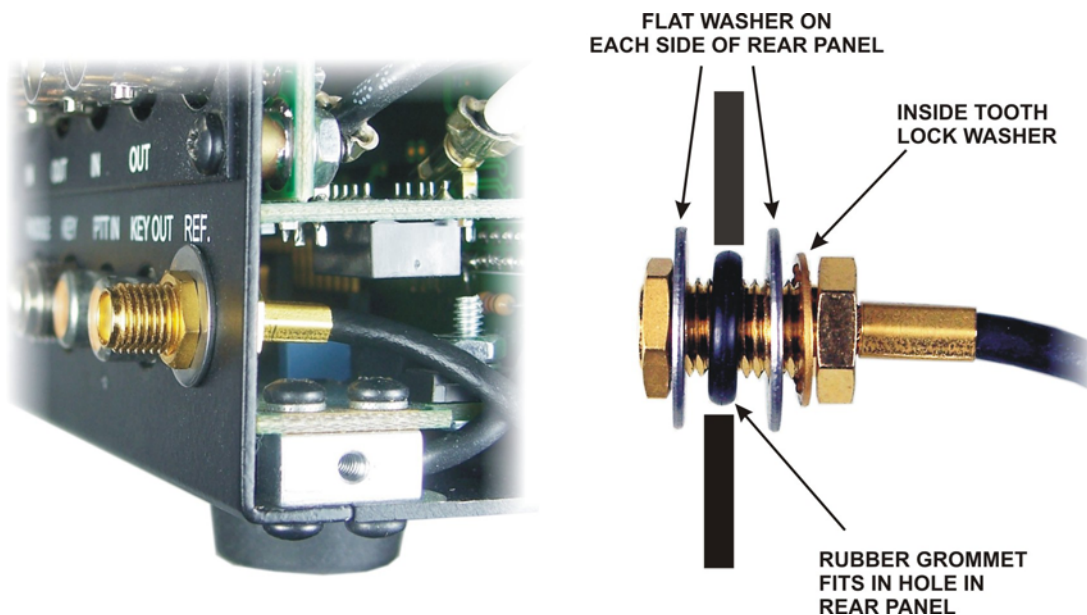

Figure 3. Mounting the SMA connector.

- Route the cable under the RF board and toward the front of the K3 as shown in Figure 4. Keep the cable near the edge of the board as shown.

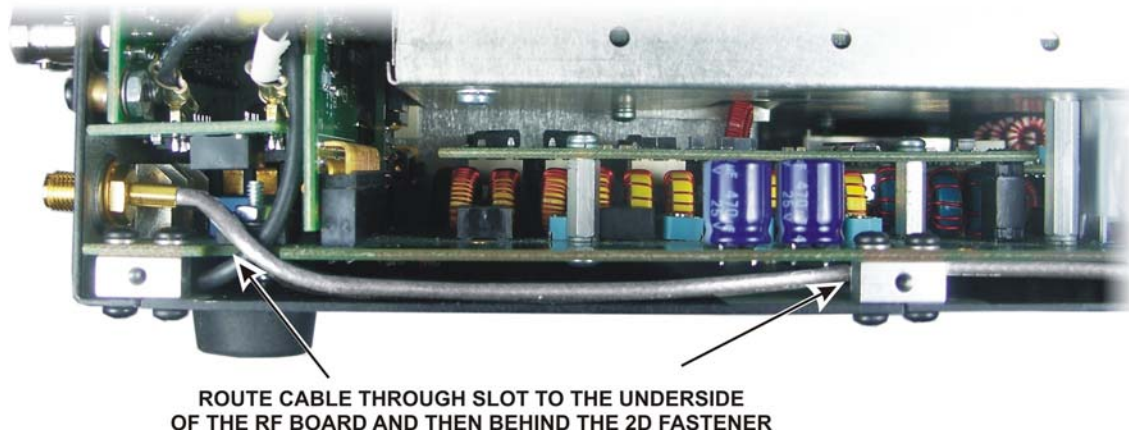

Figure 4. Routing the SMA Cable Under the RF Board.

- Route the cable through the notch near the front of the RF board and up between the front panel shield and the front panel board assembly. Bring the end of the cable up above the front panel shield behind the KREF3 board as shown in Figure 5.

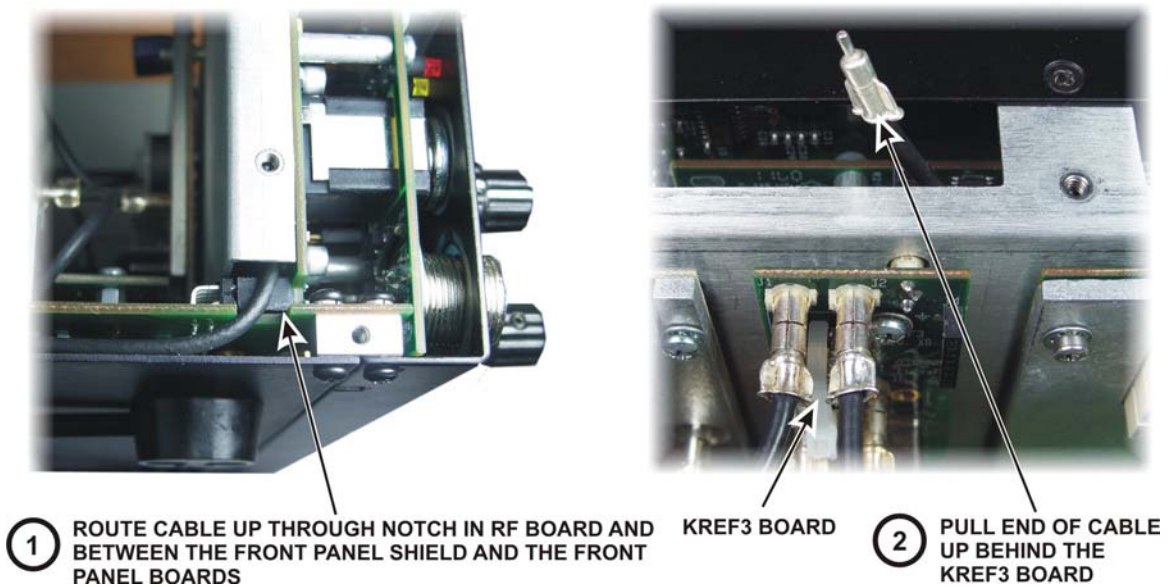

Figure 5. Routing the SMA Cable Behind the Front Panel.

Installing the K3EXREF Board

- Temporarily remove the coaxial cables at J2 and (if present) J1 on the KREF3 board. Handle the connectors by the grip (see Figure 6). Do not pull on the black coaxial cable.

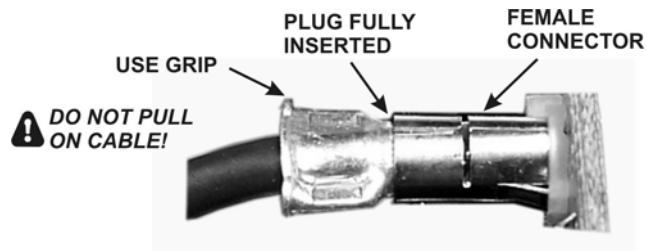

Figure 6. TMP Cable Connectors.

- Carefully remove the mounting screw and washers holding the KREF3 board (see Figure 7). As you loosen the screw tilt the top of the KREF3 board away from the front panel shield and look for a split lock washer between the front panel shield and the KREF3 board. If present, remove it with your needle nose pliers.

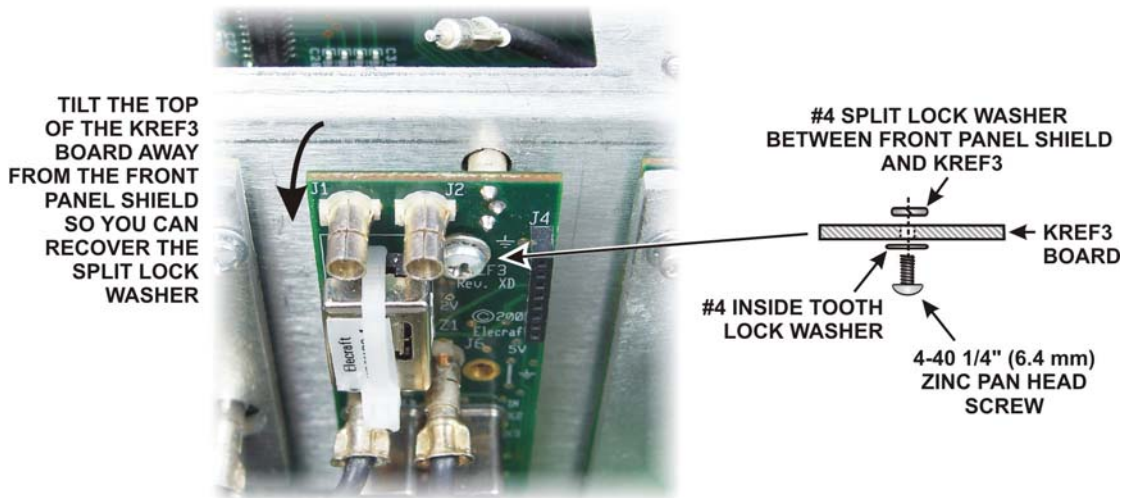

Figure 7. Removing the KREF3 Hardware.

- Check the K3EXREF board and, if not already present, install the shorting block across the center pins of J1 (see Figure 8.)

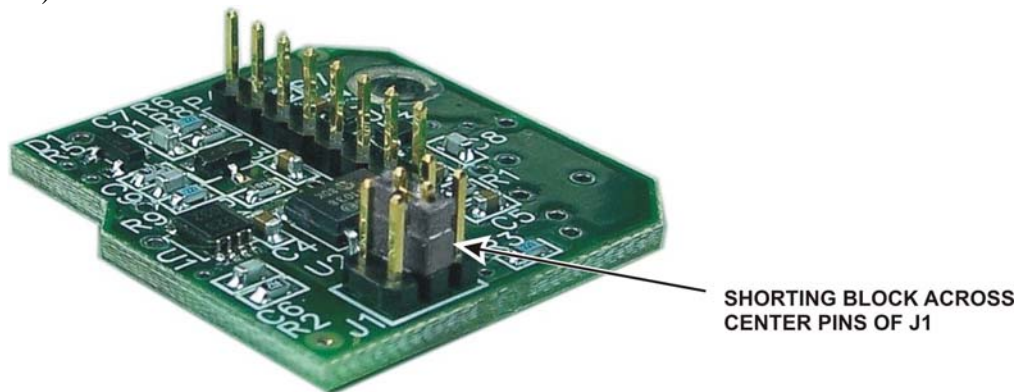

Figure 8. Shorting Block Installed on J1.

Install the K3EXREF board on the KREF3 board as follows (see Figure 9):

1. Place a #4 inside tooth lock washer on the 4-40, 5/8" (15.9 mm) pan head screw.
2. Slip the screw through the hole in the K3EXREF board with the head on the non-component side of the board.
3. Place the 1/4" (6.4 mm) spacer over the screw on the component side of the K3EXREF board.
4. Mate P4 on the K3EXREF board with J4 on the KREF3 Board while passing the screw through the hole in the KREF3 board. **Look down from the top to be sure the connector pins are properly mated.**
5. Place a #4 split lock washer on the screw behind the KREF3 board. This washer is important to ensure adequate space between the KREF3 board and the front panel shield.
6. Press the assembly toward the front panel shield so the screw lines up with the PEM nut. If necessary, press down gently on the TMP connector that passes through the front panel shield to fit it through the hole.
7. Thread the screw into the PEM nut and tighten.

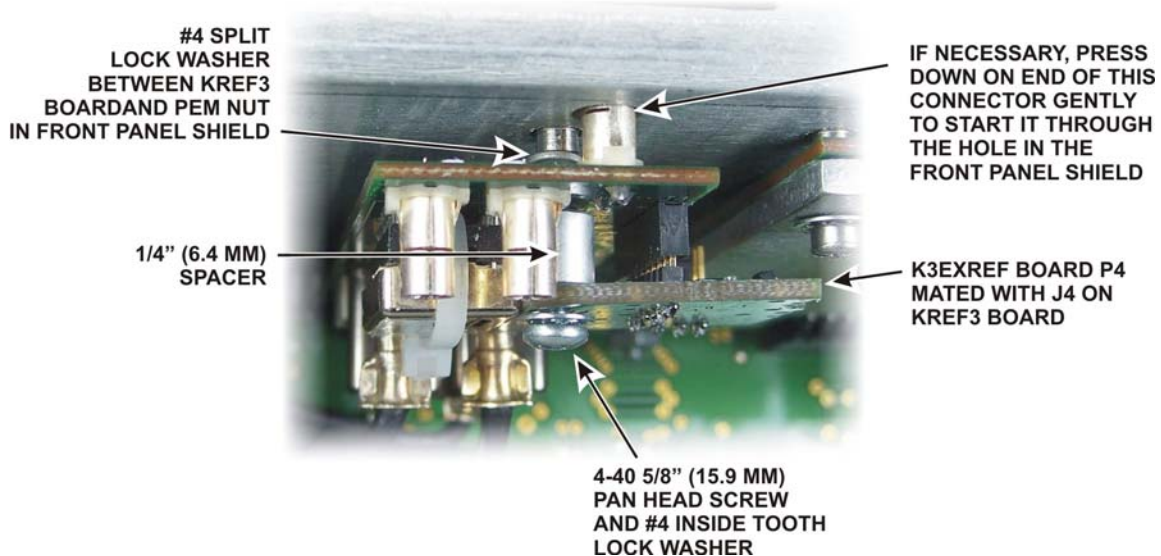

Figure 9. Mounting the K3EXREF Board on the KREF3 Board.

Plug the TMP connector on the end of the coaxial cable you installed earlier into the connector on the KREF3 board that extends through the front panel shield. Handle the connector by the grip using your needle-nose pliers. Be sure the connector is fully seated (see Figure 6 on pg 6).

Reassembly

Replace the two coaxial cables you removed from J2 and J1 (if used) on the KREF3 board earlier. If needed, see page 12 for a diagram showing the coaxial TMP cables connected to the KREF3 board.

Replace the left side panel.

- If your K3 is equipped with the K144XV 2-meter option, reconnect the coaxial TMP cables to the K144XV module and mount the module on the side panel using the three 6-32 black flat head screws you removed earlier.
- Replace the chassis stiffener bar using two 4-40 3/16" (4.8 mm) black flat head screws at the ends. If the KPA3 is installed, attach the stiffener to the shield using two 4-40 1/4" (6.4 mm) screws with lock washers under the screws. (Some stiffener bars do not have threaded PEM nuts attached. In that case, secure the screws with 4-40 nuts and place the lock washers under the nuts).
- Hold the top cover above the K3 and route the speaker wire under the stiffener bar. If you have the K144XV 2-meter option installed, route the speaker cable under the stiffener bar at the depression in the top of the K144XV module as shown in Figure 10. Plug the speaker cable into P25 on the KIO3 board at the left rear of the K3.

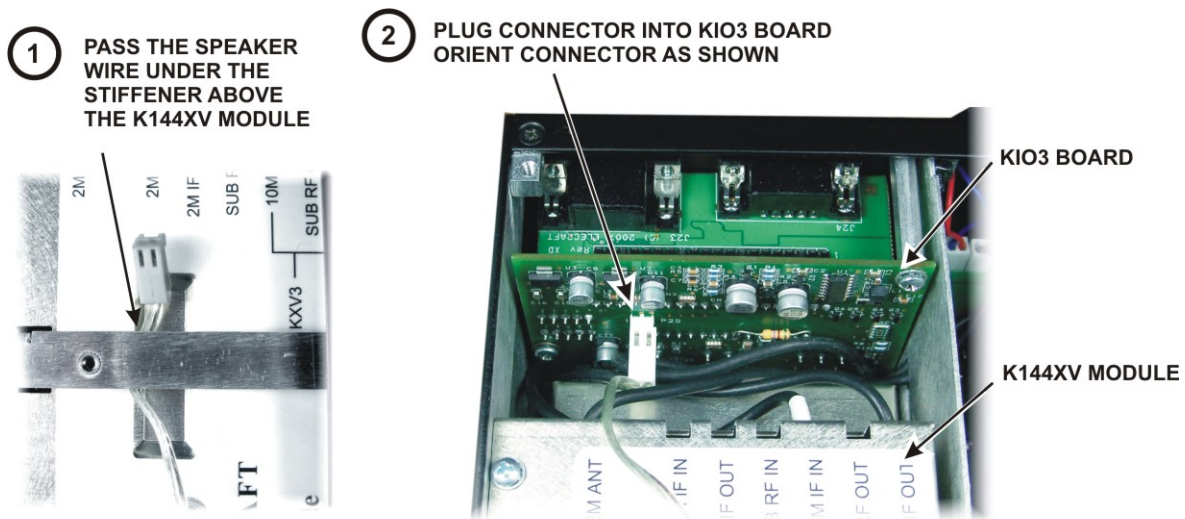

Figure 10. Connecting the Speaker Cable.

- Position the top cover on the K3. Note that the tab on the back center goes under the rear lip of the K3 rear panel. Secure the top cover with the nine 4-40 3/16" (4.8 mm) black flat head screws you removed earlier (see Figure 1 on page 6 for the screw locations).

⚠ REPLACE ALL THE SCREWS!

The K3's chassis has excellent rigidity despite its light weight. The screws that hold the top cover in place are an important part of the structural design. Please be sure to replace all the screws and verify they are tight whenever you replace the cover or other panels. When finished you should have one 1/4" 4-40 zinc pan head screw, one inside tooth lock washer and one split lock washer left over (the parts you removed from the KREF3 board).

- If needed, install the SMA-BNC adapter on the rear panel REF. connector you installed earlier.
- See *Using the K3EXREF* on pg 4 to confirm it is operating correctly.

That completes the installation of your K3EXREF Option.

Appendix A - KREF3 TMP Cable Connections

These illustrations show the TMP cable connections to the KREF3 board for reference during reassembly. Refer to *Installing the K3EXREF* on pg 4 for installation details.

Note that the K3EXREF SMA cable that connects to the KREF3 board through the hole in the front panel shield is not shown.

