



ELECRRAFT® P3

HIGH-PERFORMANCE PANADAPTER

OWNER'S MANUAL

Revision C, August 26, 2011

Copyright © 2011, Elecraft, Inc.

All Rights Reserved

Contents

NOTE: IF YOU PURCHASED YOUR P3 AS A KIT, GO DIRECTLY TO *KIT ASSEMBLY INSTRUCTIONS* ON PAGE 34 TO ASSEMBLE YOUR P3.

Key to Symbols and Text Styles.....	3	Use with Other Radios.....	22
Quick-Start Guide	4	Use with Transverters	22
Introduction.....	7	Remote-Control Commands	22
P3 Features	7	P3 Utility Program.....	22
Specifications	8	Firmware Upgrades.....	23
Customer Service and Support.....	9	Checking your Firmware Revision.....	23
Front Panel.....	10	P3 Firmware Self-Test.....	23
Control Groups.....	10	Forcing a Firmware Download.....	23
Display	11	Updating K3 Firmware.....	23
Primary Controls	11	Configuration	24
Menu	12	Calibration Procedures.....	24
Programmable Function Keys.....	12	Frequency Calibration	24
Rear Panel Connectors.....	13	Amplitude Calibration	24
Basic Operation	14	Amplitude Calibration for Transverters.....	25
Using Tap/Hold Switches	14	Menu Functions	26
Initial Power-Up.....	14	Troubleshooting	28
Configuring the Display	14	Parameter Initialization.....	28
Using the Menu	14	Theory of Operation.....	29
Programmable Functions	15	Parts List	30
Adjusting the Frequencies Displayed.....	15	P3 Sheet Metal Box - E850435	30
Using Markers.....	16	P3 Misc Bag - E850433.....	31
Waterfall Markers	16	P3 PCB Box – E850436	33
Using Cursors.....	16	Kit Assembly Instructions	34
How to Set Up and Interpret the P3 Display .	18	Preventing Electrostatic Discharge Damage.....	34
Spectrum Display	18	Tools Required	35
Waterfall Display	19	Assembly Procedure	35
Averaging and Peak Hold	19	Servicing the P3	46
Span.....	19	Accessing the PC Boards.....	46
Fixed-tune mode.....	19	Cleaning the LCD Bezel.....	46
Typical Spectra.....	20	Replacing the LCD Display.....	47
Advanced Operating Features.....	22		



Elecraft manuals with color images may be downloaded from
www.elecraft.com.

Key to Symbols and Text Styles



Important – read carefully



Operating tip

-100

Characters displayed on the LCD screen

DISPLAY

Tap switch function (labeled *above* a switch)

AVERAGE

Hold switch function (labeled *below* a switch; hold for 1/2 sec. to activate)

⌚ **SELECT**

Rotary control

⌚ **QSY**

Tap switch function of rotary control (labeled *above* the knob)

⌚ **UNDO QSY**

Hold switch function of rotary control (hold for 1/2 sec.)

MENU:Font

Typical menu entry

Quick-Start Guide

To get started using your P3 right away, please read this page and the two pages that follow, trying each of the controls. The text uses braces to refer to numbered elements in the front- and rear-panel illustrations below. For example, {1} refers to ①, the display. Later sections provide greater detail on all aspects of P3 operation.

⚠ The first thing you need to know about the P3 is that most switches have two functions. **Tap** (*press briefly*) to activate the function labeled **above** a switch. **Hold** activates the function labeled **below** the switch. In the text, tap functions are shown like this: **DISPLAY**. An example of a hold function is **AVERAGE**. Additional typographical conventions are shown on the previous page.

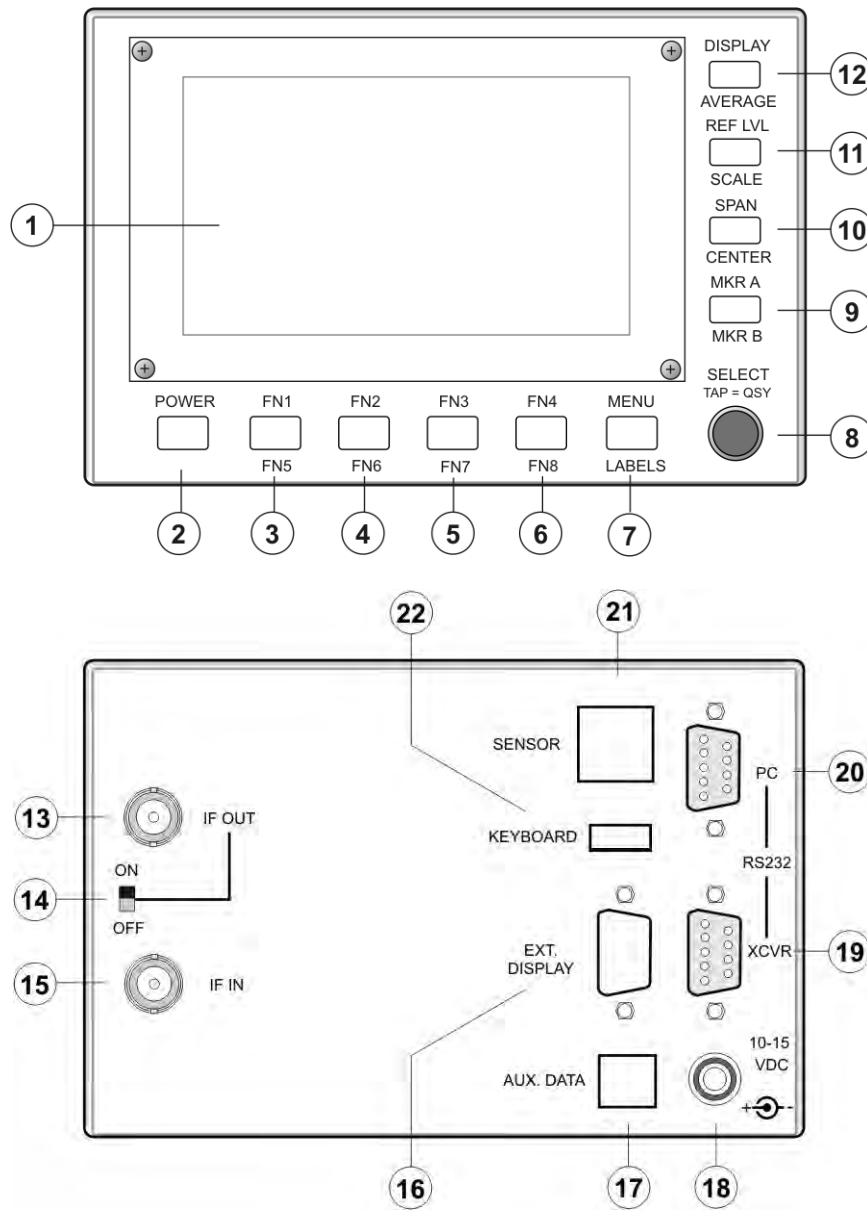

⚠ IMPORTANT

K3's built before September 2009 should have the I.F. Buffer Gain Modification installed for best weak-signal display on the P3. This modification changes a single resistor to increase the I.F. output from the K3 by about 10 dB. A modification kit consisting of the resistor and installation instructions is included with your P3.

This modification is not required for K3 RF boards version H3 and later.

<p>Connections</p> 	<ul style="list-style-type: none"> • Connect a power supply to the DC input jack {18} (see Specifications, pg. 8). When used with a K3, this power may be taken from the 12VDC OUT jack on the K3 rear panel. ⚠ The K3 is capable of supplying power to both the P3 and the Elecraft PR6 six-meter preamplifier at the same time if 12VDC or greater is supplied to the K3's power connector. Lower voltages at the K3 connector will cause the total current required by the P3 and PR6 to exceed the 500 mA limit from the K3's 12VDC outlet. • Connect a coaxial cable between the IF IN {15} and the I.F. output of your transceiver. When used with a K3, connect the cable to the IF OUT on the K3's rear panel.. • When used with a K3, connect a Male-Female DE-9 cable between the P3 XCVR connector {19} and the K3's rear-panel RS232 connector. • Connector openings {16}, {17}, {21}, and {22} are provided for future use.
<p>The Basics</p>	<ul style="list-style-type: none"> • Turn on the power supply that is supplying the P3. If power is obtained from the 12VDC OUT jack of a K3, turn on the K3. If necessary, press POWER {2} to turn on the P3. You can position a jumper to have the P3 turn on automatically with the K3 (Pg 24). • TAP and HOLD Functions: <i>Tapping</i> briefly activates the function labeled in white <i>above</i> a switch. <i>Holding</i> for about 1/2 second activates the function labeled in yellow <i>below</i> a switch. Try tapping MENU {7} to bring up the main menu. Rotate SELECT {8} knob to scroll through the menu entries. Tapping the knob selects the entry currently displayed. Tap the knob again to deselect the entry. Tap MENU {7} to exit the menu. • Tap DISPLAY {12} to cycle between spectrum and waterfall display modes (Pg 14). • Activating many functions enables the SELECT {8} knob so you can adjust the parameter associated with the function. The current parameter value is shown on the screen {1}. You can exit and save the parameter by tapping the same key a second time, even for hold functions. • For hold functions, you can also hold the key a second time to exit parameter-entry mode. In the case of the hold functions associated with the four keys along the right edge of the front panel {9-12}, holding the key a second time also de-activates the function itself. For example, holding (CENTER) a second time returns the display center frequency to the transceiver frequency and holding (MKR B) a second time turns off marker B. • For best frequency accuracy, especially when using narrow spans, perform the frequency calibration procedure described on page 24.

Other Features

- Hold **LABELS** {7} to toggle on or off the function key labels located at the bottom of the screen, just above the function keys (Pgs 11 and 12).
- Tap **MENU** {7} and use the **SELECT** knob {8} to scroll through the list. You can tap or hold one of the function keys {3-6} to assign the currently-displayed function to the key. If the function key labels are on, the label for that key will change to show the selected function (Pg 11).
- Tapping the **SELECT** knob {8} while the menu is active causes the currently-selected menu function to execute. Select *LCD Brt* from the menu and tap the knob. The knob now adjusts the brightness of the LCD display backlight. Tap the knob again to exit the selection or tap **MENU** {7} to select a different menu item. Some menu items are toggle functions. Instead of changing the parameter by turning the **SELECT** knob, it changes automatically whenever the knob is tapped. The new value is displayed briefly near the top of the spectrum display. Menu items are listed on page 26.
- Tap **MKR A** {9} or hold **MKR B** {9} to turn on marker A or B. Rotate the **SELECT** knob to place the selected marker at a desired frequency on the display. Markers may be used to measure the frequency of an interesting signal and, if the transceiver is a K3, tapping the knob will QSY (change the frequency of) the K3 to that frequency. **MKR A** controls the K3's VFO A and **MKR B** controls VFO B. The marker colors match the corresponding VFO cursors to emphasize the correspondence. Whichever marker is currently selected is the one that causes the K3 to QSY (Pg 11).
- To return from the last QSY ("undo" function), *hold* the **SELECT** knob pushbutton. To turn off marker A, tap **MKR A** {9} while marker A is selected. To turn off marker B, hold **MKR B** {9} while marker B is selected.
- Tap **SPAN** {10} to set the frequency span of the display. The start and stop frequencies are displayed at the top (left and right edge respectively) of the spectrum window (Pg 11).
- Hold **CENTER** {10} to set the center frequency of the display (Pg 12). This function may be disabled when in tracking mode via the MENU:CenterEn function.
- Tap **REF LVL** {11} to set the amplitude reference level of the display, both spectrum and waterfall. The term "reference level" means the signal level that corresponds to the bottom of the spectrum display (Pg 12).
- Hold **SCALE** {11} to set the scale, or range, of both the spectrum and waterfall displays. For example, "60 dB" means that the bottom of the display is 60 dB below the top (Pg 12).
- Hold **AVERAGE** {12} to turn on display averaging and allow adjustment of the averaging time (Pg 12).

Introduction

This comprehensive manual covers all the features and capabilities of the Elecraft P3 panoramic display. We recommend that you begin with the **Quick-Start Guide** (pg. 4). The **Front Panel** (pg. 10) and **Rear Panel** (pg. 13) sections are for general reference. **Basic Operation** (pg. 13) and **Advanced Operation** (pg. 17) fill in the details.

P3 Features

The P3 offers a number of advanced features to enhance performance and versatility:

Compatible Receivers/Transceivers

- May be used with any receiver having an I.F. output between 455 kHz and 21.7 MHz (including the Elecraft K2 with suitable modification). The P3 is usable with frequencies as low as 300 kHz.
- Integrates very closely with the Elecraft K3 with point-and-click QSY and an “undo” feature with simple control press to return to the previous frequency.

Easy Set-Up

- Only two cables for basic operation (I.F. and power).
- Optional additional connections provided for transceiver communications, a personal computer and optional accessories.
- No configuration or calibration is required.

Display

- Bright, high-resolution, full color display.
- Efficient LED backlight for long life and low power consumption.
- Both fixed-tune and transceiver-tracking modes for the display frequency.
- Both Spectrum and Waterfall displays.
- Fast display update.
- Up to 200 kHz span.
- Frequency resolution automatically increases as span is decreased.
- Excellent sensitivity and dynamic range.

Ergonomic Design

- Uncluttered interface.
- No unused controls on the screen.

Field Upgradable

- Software defined architecture so many new features will require only a simple firmware update using the provided PC utility program.
- Room inside for future hardware updates.

Specifications

I.F. Frequency Range:	455 kHz to 21.7 MHz (usable with frequencies as low as 300 kHz)
Noise Figure:	< 10 dB measured at P3 input typical
Blocking Dynamic Range:	> 120 dB (500 Hz bandwidth) typical
Absolute Level Accuracy:	± 3 dB plus display resolution after calibration at S9 (-73 dBm)
Relative Level Accuracy:	± 0.1 dB plus display resolution
Display Update Rate:	Selectable 1 Hz to 20 Hz (slower at narrowest spans)
Amplitude Scale:	10 dB minimum, 80 dB maximum
Span:	2 kHz minimum, 200 kHz maximum
Resolution Bandwidth:	Span / 450, 8 Hz minimum
Power Requirements:	10 to 15 VDC, 0.5 A maximum
Weight:	5.5 lbs (2.5 kg)
Size:	Enclosure only, 4.0 x 6.1 x 10.0 in., HWD (10.2 x 15.6 x 25.4 cm). With projections, 4.4 x 6.1 x 11.8 in. (11.2 x 15.6 x 30.0 cm).

Customer Service and Support

Technical Assistance

You can send e-mail to k3support@elecraft.com and we will respond quickly – typically the same day Monday through Friday. If you need replacement parts, send an e-mail to parts@elecraft.com. Telephone assistance is available from 9 A.M. to 5 P.M. Pacific time (weekdays only) at 831-763-4211. Please use e-mail rather than calling when possible since this gives us a written record of the details of your problem and allows us to handle a larger number of requests each day.

Repair / Alignment Service

If necessary, you may return your Elecraft product to us for repair or alignment. (Note: We offer unlimited email and phone support, so please try that route first as we can usually help you find the problem quickly.)

IMPORTANT: You must contact Elecraft before mailing your product to obtain authorization for the return, what address to ship it to and current information on repair fees and turnaround times. (Frequently we can determine the cause of your problem and save you the trouble of shipping it back to us.) Our repair location is different from our factory location in Aptos. We will give you the address to ship your kit to at the time of repair authorization. *Packages shipped to Aptos without authorization will incur an additional shipping charge for reshipment from Aptos to our repair depot.*

Elecraft 1-Year Limited Warranty

This warranty is effective as of the date of first consumer purchase (or if shipped from the factory, the date the product is shipped to the customer). It covers both our kits and fully assembled products. For kits, before requesting warranty service, you should fully complete the assembly, carefully following all instructions in the manual.

Who is covered: This warranty covers the original owner of the Elecraft product as disclosed to Elecraft at the time of order. Elecraft products transferred by the purchaser to a third party, either by sale, gift, or other method, who is not disclosed to Elecraft at the time of original order, are not covered by this warranty. If the Elecraft product is being bought indirectly for a third party, the third party's name and address must be provided at time of order to ensure warranty coverage.

What is covered: During the first year after date of purchase, Elecraft will replace defective or missing parts free of charge (post-paid). We will also correct any malfunction to kits or assembled units caused by defective parts and materials. Purchaser pays inbound shipping to us for warranty repair; we pay shipping to return the repaired equipment to you by UPS ground service or equivalent to the continental USA and Canada. For Alaska, Hawaii, and other destinations outside the U.S. and Canada, actual return shipping cost is paid by the owner.

What is not covered: This warranty does not cover correction of kit assembly errors. It also does not cover misalignment; repair of damage caused by misuse, negligence, or builder modifications; or any performance malfunctions involving non-Elecraft accessory equipment. The use of acid-core solder, water-soluble flux solder, or any corrosive or conductive flux or solvent will void this warranty in its entirety. Also not covered is reimbursement for loss of use, inconvenience, customer assembly or alignment time, or cost of unauthorized service.

Limitation of incidental or consequential damages: This warranty does not extend to non-Elecraft equipment or components used in conjunction with our products. Any such repair or replacement is the responsibility of the customer. Elecraft will not be liable for any special, indirect, incidental or consequential damages, including but not limited to any loss of business or profits.

Front Panel

This section describes all front panel controls and the liquid crystal display (LCD). Operating instructions are covered in later sections.

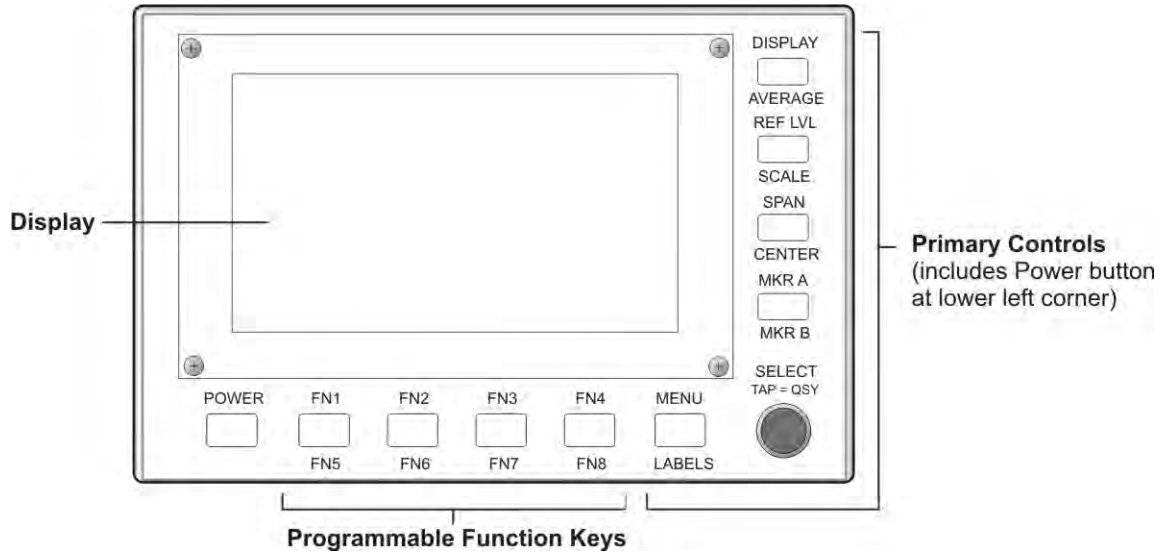

Control Groups

Primary controls (pg 11): These keys are hard-coded with permanent function assignments. They provide the most important operational features needed for basic panadapter operation, including display options, amplitude scaling, frequency control and markers.

Programmable function keys (pg 12): The function keys may be assigned to any of the functions in the MENU list. These include less-used operational features, test functions, and setup and calibration routines.

Display

The 480x272-pixel, color TFT-LCD display is used both for the panadapter spectrum and waterfall graphics as well as for general-purpose information needed by the operator. All graphics and text are

bit-mapped and so are software-defined. The backlight brightness and the text size can be changed via a **MENU** entry (Pg 26).

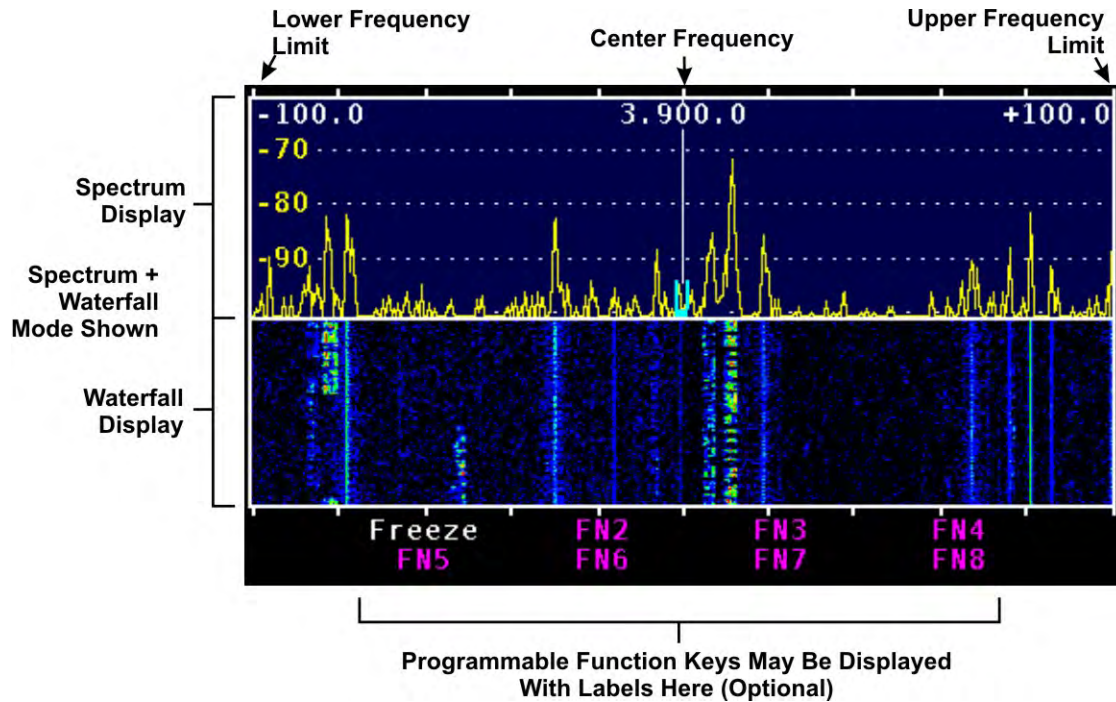

Primary Controls

POWER Turns the P3 on or off. The P3 may be configured to turn on automatically whenever power is applied, such as when it is powered from a K3 transceiver, by moving a jumper on the rear-panel I/O board (see *Configuration* on page 24 for details.) Holding the POWER switch for more than 10 seconds places the P3 in boot-load mode, ready to receive new firmware via the RS232 PC connector. If you do this accidentally, simply cycle the POWER to restore normal operation.

MKR A and **MKR B** Selecting one of these functions causes a marker to appear on the display, using different colors for A and B. The marker frequency can be adjusted by turning the **SELECT** knob. If the transceiver is a K3 and it is connected to the P3 via RS232, then tapping the knob changes the frequency of (QSY) the K3 to that frequency. **MKR A** controls the K3's VFO A and **MKR B** controls VFO B. The marker colors match the corresponding VFO cursors to emphasize the

correspondence. Whichever marker is currently selected is the one that causes the K3 to QSY. To return from the last QSY ("undo" function), hold the **SELECT** knob pushbutton.

To turn off **MKR A**, tap the key while marker A is selected. To turn off **MKR B**, hold the key while marker B is selected. When a marker is turned back on after having been turned off, it will come back at the same frequency unless it is off-screen, in which case the marker defaults to the center frequency.

When another function that uses the **SELECT** knob is activated, the marker(s) stay visible and when that other function is de-selected the last active marker automatically becomes active again.

SPAN Sets the frequency span of the display. The available range is 2 kHz to 200 kHz. The start and stop frequencies are displayed at the top (left and right edge respectively) of the spectrum window.

CENTER sets the center frequency of the display, which is also displayed at the top center of the spectrum window when in tracking mode. If MENU:CenterEn is set to OFF, then this function is disabled for tracking mode. If the transceiver is a K3, the center frequency defaults to the VFO A frequency of the K3, but it may be tuned above and below that value. It will then track any changes in the K3's VFO A.

In fixed-tune mode as well, **CENTER** sets the center frequency of the display, however it does not track the K3 VFO but stays at a fixed frequency. If desired, you can set the center frequency to re-adjust automatically by setting the proper mode in MENU:FixMode. In both fixed and tracking modes, hold the **CENTER** key a second time to return the center frequency to the K3's VFO A frequency.

REF LVL Sets the amplitude reference level of the display, both spectrum and waterfall. The term "reference level" means the signal level that corresponds to the bottom of the spectrum display and the minimum signal level (dark blue) of the waterfall. The amplitude labels that appear along the left edge of the spectrum display may be in dBm or S-units plus dB over S9, depending on the setting of MENU:Lvl Mode. If the transceiver is a K3, the amplitude is that of the signal at the K3 antenna input, with the state of the K3's attenuator and preamp taken into account. Tap any key to de-select the parameter entry.

SCALE Sets the scale, or range, of both the spectrum and waterfall displays. For example, "60 dB" means that the bottom of the display is 60 dB below the top. Tap any key to de-select the parameter entry.

DISPLAY Toggles between the spectrum, and combination spectrum/waterfall display modes.

AVERAGE Turns on display averaging and allows adjustment of the averaging time, in units of the display update period. To de-select parameter entry and turn off averaging at the same time, *hold* the key a second time. To de-select parameter entry while leaving averaging turned on, *tap* the key.

Menu

MENU Accesses an alphabetical list of functions (see Menu Functions, pg.26). Scroll through the list with the **SELECT** knob and tap the knob to select an item. For items with only two or three items, tapping the **SELECT** knob automatically toggles between parameter values. For other items, you can turn the **SELECT** knob to choose the parameter value. Tapping the knob a second time un-selects the item and exits the menu. If you wish to terminate the item but keep the menu active, tap **MENU**. When you wish to exit the menu, tap **MENU** again.

Programmable Function Keys

Most menu functions can be assigned to a function key by tapping or holding the **FN1** – **FN4** or **FN5** – **FN8** key while the menu item is displayed but not selected. The label for that function key will then change to the function name (when labels are turned on with the **LABELS** key).

LABELS toggles the function key labels on and off. Note that the function keys are still active even when the labels are turned off.

Rear Panel Connectors

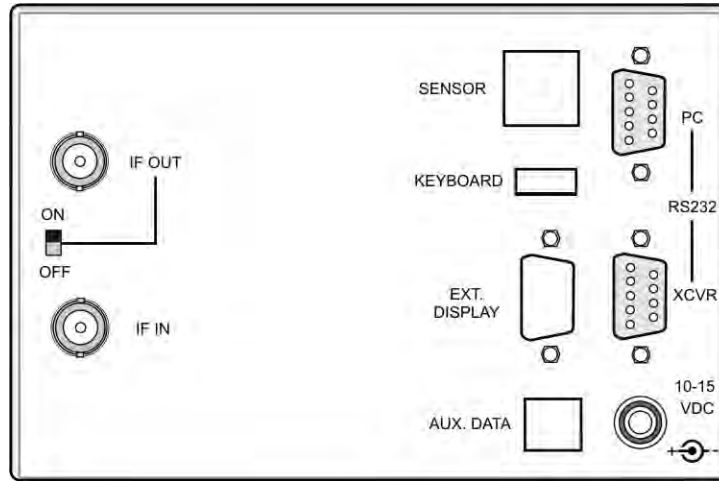

I.F. Signals: **IF IN** is a BNC jack that connects to the intermediate-frequency output connector of the transceiver (IF OUT on the K3). This should be a buffered, low-level, high-bandwidth signal from the receiver that is tapped off at a point before the high-selectivity filters.

IF OUT is a BNC jack that may be connected to any other device that needs the I.F. output signal from the transceiver. When the IF OUT switch is in the ON position, the IF IN signal is directed to a 3 dB splitter whose outputs feed both the P3 and the IF OUT connector.

RS232 XCVR is a male DE-9 connector that connects to the RS232 port on a K3 (if used) using a standard 9-pin serial extender cable. It should be a straight-through cable (not a null modem) with a female connector on one end and male connector on the other. Note that communications between the

K3 and the P3 are always at a data rate of 38400 baud (see figure below). The K3 baud rate is set automatically by the P3 and cannot be changed at the K3.

RS232 PC is a female DE-9 that optionally may be connected to a personal computer that can be used for downloading new firmware and for sending and receiving commands to the P3 and K3 (if connected). To set the baud rate, refer to the RS232 Menu entry on page 26. The baud rate also may be set by using the same RS232 command (BR) as for a K3. Refer to the *K3 or P3 Programmer's Reference* for details. To download firmware to the K3, see *Updating K3 Firmware* on page 23.

Power: 10-15 VDC is a standard 2.1 mm barrel connector for a 10-15 VDC supply capable of delivering up to 0.5A.

SENSOR, KEYBOARD, EXT.DISPLAY and AUX DATA: Spaces for these connectors provided for future use.

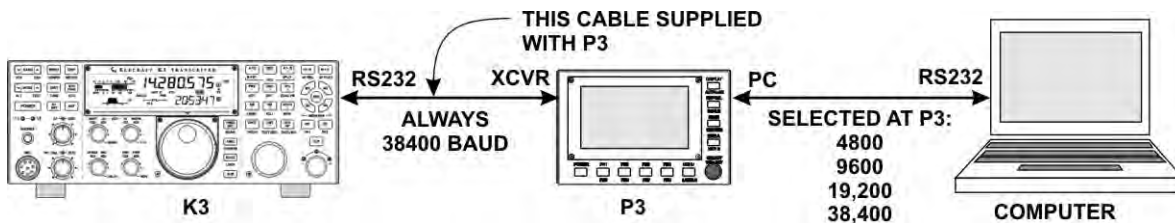

RS232 Communications Path through the P3.

Basic Operation

This section covers the fundamentals of P3 operation. Once you're familiar with the P3, please go on to *Advanced Operating Features* (pg.17).

Using Tap/Hold Switches

Most P3 switches have two options. **Tapping** (pressing for less than 1/2 second) activates the function labeled in white above the switch. **Holding** (pressing for more than 1/2 second) activates the function labeled in yellow below the switch.

Initial Power-Up

- Connect a power supply, I.F. input and (optionally) an RS232 cable (pg 13).
- Press **POWER** to turn the P3 on, if it is not on already. The screen should light and you should see a spectrum or combined spectrum and waterfall display. If a K3 is connected via RS232 you should see the correct frequency at the top center of the display.

Configuring the Display

Tap **DISPLAY** to cycle between spectrum and combined spectrum and waterfall displays.

Hold **AVERAGE** to turn on averaging and to set the averaging time constant with the **SELECT** knob.

You can hold **AVERAGE** again to turn off averaging or just tap the same key to clear the parameter-entry text from the display while leaving averaging enabled.

Hold **LABELS** to show or hide the function key labels.

There are also several MENU functions that configure the display, such as *LCD Brt* (display brightness), *Peak hold*, *Freeze display*, *Font size* and *Waterfall height*.

Using the Menu

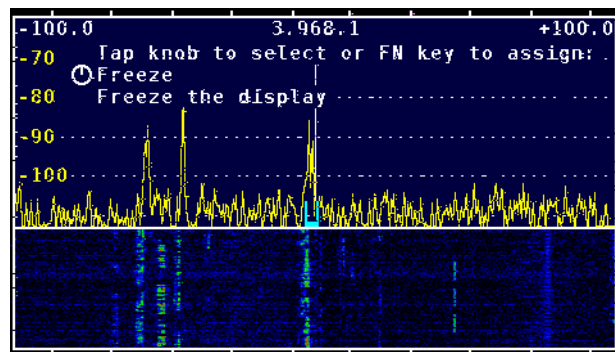

Typical Display Showing a Menu Selection.

- Tap **MENU** to access the menu.
- Turn the **SELECT** knob to scroll through an alphabetical list of available menu functions, as documented in the Menu Functions section (pg.26).
- Tap the **SELECT** knob to select a function.
- Most functions have a parameter which can then be adjusted with the **SELECT** knob.
- Tap the **SELECT** knob again to exit the function.
- Tap **MENU** again to exit the menu.
- Some menu items are toggle functions. The parameter changes automatically every time you tap the **SELECT** knob.

Programmable Functions

Most MENU functions can be assigned to any programmable function key, FN1 to FN8. Tap or hold the desired function key while the function is visible on the display but *not* selected by tapping the  **SELECT** knob. The function name then becomes the function key label which can be seen if labels are currently displayed. To un-assign a function key, select *MENU:FN Erase* and tap or hold the function key you wish to erase.

Some menu items are much more useful when assigned to a function key. Examples are *Peak* hold and *Freeze* display.

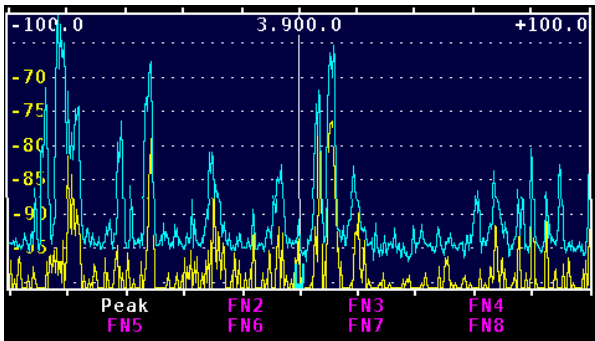

PEAK assigned to Function Key FN1.

Adjusting the Amplitude

Tap **REF LVL** to adjust the reference level, which is the signal level that corresponds to the bottom of the spectrum display and the low-signal level of the waterfall display. Hold **SCALE** to adjust the "vertical gain" of the display. For example if the reference level is set to -100 dBm and the scale to 30 dB, then the top of the spectrum display is at -70 dBm and the bottom at -100 dBm.

The waterfall display is most useful if the reference level is adjusted to place the noise level near the bottom of the display and the scale is adjusted so that the strongest signals of interest are near the top.

Adjusting the Frequencies Displayed

Tap **SPAN** to adjust the range of frequencies that can be seen on the display at one time. The start and stop frequencies are indicated at the top left and right of the display. They are shown as offsets from the center frequency in tracking mode and as the actual RF frequencies in fixed-tune mode.

Hold **CENTER** to adjust the display center frequency by turning the  **SELECT** knob. This function may be disabled for tracking mode via *MENU:CenterEn*.

Hold **CENTER** again to re-center the display on the transceiver VFO frequency.

When used with the K3, an RF frequency is shown at the top center of the display. In tracking mode, it is the display center frequency, which normally is the K3 VFO A frequency. In fixed-tune mode it is always the K3 VFO A frequency. For transceivers other than the K3 it is the difference between the center frequency and the current transceiver frequency, normally zero.

The tic marks that appear along the top and bottom edges of the spectrum and waterfall widows indicate RF frequency in integer multiples of 0.5, 1, 2, 5, 10 or 20 kHz, depending upon the span.

Using Markers

Tap **MKR A** to turn on marker A and allow you to change the marker frequency by rotating the **SELECT** knob. To determine the frequency of a signal, move the marker so that it overlays the carrier and read the frequency from the display. For single sideband signals, place the marker where the carrier would be if it were transmitted, i.e. on the lower (left) edge of an upper sideband signal and on the upper (right) edge of a lower sideband signal.

If a K3 is connected, you can QSY (change the frequency of) the K3's VFO A to the marker A frequency by tapping the **SELECT** knob. To return to the previous frequency, hold the knob. To turn off marker A, tap **MKR A** again.

Hold **MKR B** to turn on marker B and allow you to change the marker frequency by rotating the **SELECT** knob. If a K3 is connected, you can QSY the K3's VFO B to the marker B frequency by tapping the **SELECT** knob. To return to the previous frequency, hold the knob. To turn off marker B, hold **MKR B** again.

To turn off a marker you must first make it active, if necessary, by tapping **MKR A** or holding **MKR B**. Then tap or hold the key a second time to hide the marker.

If some other function that uses the **SELECT** knob is activated, the marker stays on and automatically becomes active again (you can adjust it with the knob) when the other function is terminated. The tap-to-QSY function affects VFO A if marker A is active and VFO B if marker B is active.

When a marker is turned on, it will be at the same frequency as the last time it was on unless that frequency is off-screen. In that case the marker is automatically reset to the display center frequency. (If you lose a marker off-screen, just turn it off and on again to return it to the center frequency.)

When you change bands on the K3, the markers are automatically set at the new center frequency.

For best frequency accuracy, especially when using narrow spans, perform the frequency calibration procedure on page 24.

Waterfall Markers

Select *MENU:WfallMkrs*. Tapping the **SELECT** knob will turn the waterfall markers on, causing the marker line(s) to travel down into the waterfall display, or turn the markers off.

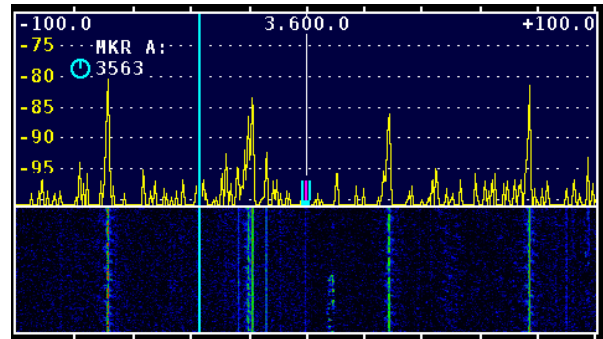

Marker A Enabled at 3563 KHz for Both Spectrum and Waterfall.

Using Cursors

When used with a K3 transceiver, cursors show the position of the A and B VFOs, The position and width of each cursor shows the passband being received. Two cursor shapes may be selected using *MENU:Cursors*, a translucent bar cursor or a “U” shaped cursor at the bottom of the spectrum display.

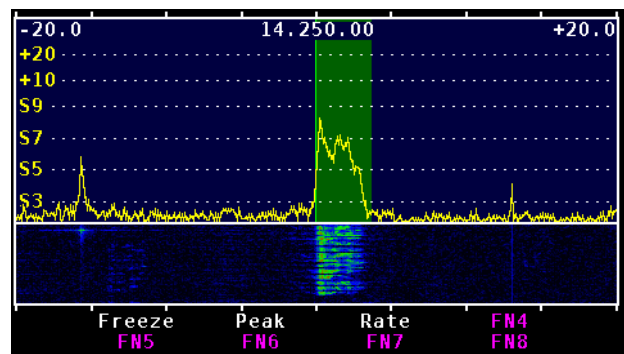

Bar Cursor on Upper Sideband Signal at 14.250 kHz

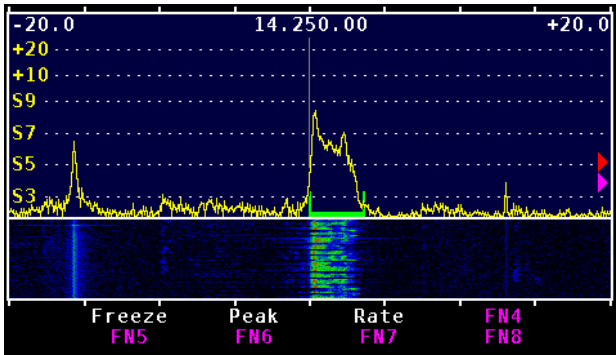

“U” Cursor on Upper Sideband Signal at 14.250 kHz

VFO A has a green cursor and VFO B has a magenta cursor unless split mode is activated at the K3. In split mode, the VFO B cursor changes to red as a reminder that you will transmit on that frequency. Similarly, if XIT is on, or if split is off and RIT is on, a new red cursor appears at the transmit frequency.

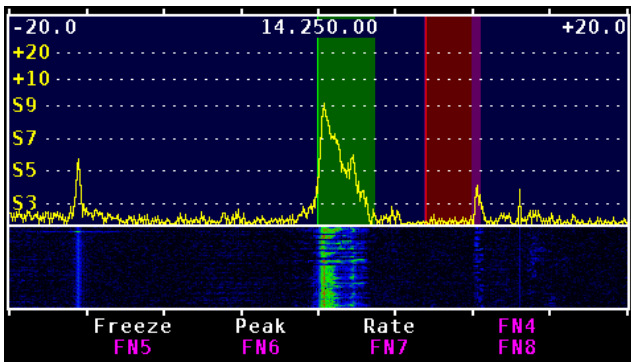

Red Bar Cursor Showing Transmit Frequency Above the Receive Frequency

Whenever a cursor is tuned off-screen a small arrow of the same color appears at the bottom left or right of the spectrum window to indicate the direction to the missing cursor

The VFO B cursor may be turned off using *MENU:VFO B*. Tap the knob to select *ON* or *OFF* as desired.

How to Set Up and Interpret the P3 Display

There are several options to customize the layout of your P3 display. **DISPLAY** switches between a spectrum-only and spectrum-plus-waterfall display. The height of the waterfall can be adjusted with *MENU:Waterfall*. The function (FN) key labels appear at the bottom of the screen by default. You can hide them to maximize the screen area by holding **LABELS**. The FN keys remain active even when the labels are hidden. Another trick to maximize viewing area is to choose a smaller type font via *MENU:Font*.

Spectrum Display

The spectrum display on a panadapter is similar to the display on a laboratory spectrum analyzer. The horizontal axis is frequency and signal strength is represented by the vertical height of each signal. The P3's spectrum display is similar to most in that the signal height is proportional to the logarithm of the amplitude, represented in decibels (dB). Each 3 dB represents a doubling of power and 10 dB means ten times the power.

The vertical scale at the left edge of the spectrum display may be in units of dBm or S-units, as selected by *MENU:Lvl Mode*. The dBm unit means decibels with respect to one milliwatt. 0 dBm is one milliwatt, +10 dBm is 10 milliwatts, -10 dBm is 1/10 milliwatt and so on. An S9 signal is normally considered to be 50 microvolts into 50 ohms, which is -73 dBm, an easy number for a ham to remember! Assuming the standard 6 dB per S-unit, the following table applies.

S-Units	Signal Level	
S9	-73 dBm	50 μ V
S8	-79 dBm	25 μ V
S7	-85 dBm	12.5 μ V
S6	-91 dBm	6.25 μ V
S5	-97 dBm	3.13 μ V
S4	-103 dBm	1.56 μ V
S3	-109 dBm	0.78 μ V
S2	-115 dBm	0.39 μ V
S1	-121 dBm	0.2 μ V

You would expect the S meter on the K3 and the signal on the P3 display to indicate the same level if both the K3 and the P3 are properly calibrated, however there are several reasons why that might not be the case. One is that the P3 is not affected by the preamplifier and attenuator in the K3. If the *K3 CONFIG:SMTR MD* is set to *NOR*, the S meter reading changes when you turn on or off the preamplifier and attenuator. To prevent that, change the setting to *ABS*.

The noise level will generally be lower on the P3 display compared to the K3 S meter. The reason is that the effective bandwidth of the P3 is generally one display pixel, which is approximately span / 450. The smaller the bandwidth, the less noise. For example, if the span is 45 kHz, the effective P3 bandwidth is $45,000 / 450 = 100$ Hz. If the K3 bandwidth is 400 Hz, it will show a 6 dB (one S-unit) higher noise level than the P3.

A similar thing happens with spread-out signals like SSB. Even at the maximum 200 kHz span, the P3's effective bandwidth is only about 440 Hz so that not all the SSB signal is within one pixel. That's why the P3 tends to read a lower level on SSB signals than the K3 S meter.

REF LVL (reference level) on the P3 shifts all the signals up or down. The level that you are adjusting is the signal level at the bottom of the display, measured in dBm.

SCALE is used to expand or contract the vertical scale. Think of it as a vertical gain control. The scale is defined as the dB difference between the top and the bottom of the display. For example, if the reference level is -100 dBm and the scale is 20 dB, then a signal at the top of the display is at -80 dBm. For both **REF LVL** and **SCALE**, turning the knob clockwise makes the signals taller.

The P3 automatically compensates for the preamplifier and attenuator in the K3. When you turn them on or off, the signal levels on the P3 should stay the same. If the I.F. output modification has been done on the K3 (see note at the top of page 5), the indicated dBm level should be the signal level at the K3 antenna input. Perhaps counter-intuitively, this means that if you turn on

the preamplifier in the K3, the noise level displayed on the P3 may decrease, rather than increase. That is because the P3 automatically reduces its gain when the K3 preamplifier is turned on, in order to keep the signal levels the same.

Waterfall Display

The waterfall allows you to see a history of band activity for the past few seconds. Like the spectrum display, the horizontal axis is frequency but in this case the vertical axis is time. Signal amplitude is represented by colors, from dark blue for weak signals, then brighter blue as signals increase in strength, through shades of green, yellow and red for the strongest signals. Each horizontal line represents one update of the spectrum display. As each new line is written the old ones are shifted down, creating a waterfall effect.

While the spectrum display is better at accurately displaying signal strength and the shape of a signal's modulation, it can only show what is happening right now. The waterfall is better for showing transient signals, such as a DX station running a pileup that only transmits for a few seconds at a time. Often, you can easily see a weak fading signal on the waterfall that is invisible on the spectrum display.

The scaling of the waterfall is the same as for the spectrum. That is, the bottom of the spectrum display corresponds to dark blue on the waterfall and the top corresponds to bright red. For maximum visibility of signals on the waterfall, it is best to set **REF LVL** so that the noise level is right at the bottom of the spectrum display and then expand **SCALE** as much as possible while keeping signals of interest below the top of the spectrum display. That improves the color contrast on the waterfall and makes weak signals appear to pop out of the noise.

Averaging and Peak Hold

Another way to make weak signals more visible is averaging. Because noise is random in nature, averaging reduces the jaggedness of the noise spectrum trace, making signals easier to pick out. The more averaging the better the noise reduction, but at the expense of a slower response. To turn on averaging and adjust the averaging time, hold

AVERAGE and then turn the knob. The averaging time is in units of the spectrum update rate, typically about 50 ms. You can apply averaging to the waterfall as well by setting *MENU:Wfall Avg* to *On*.

Peak hold is a way to display a memory of past signals on the spectrum display. It shows the strongest signals that have appeared at each frequency since the last time peak mode was enabled. To reset the peak trace, simply disable peak hold and then re-enable it. This mode is most useful if you assign *MENU:Peak* to a FN key so you can turn it on and off at the touch of a button.

One use for peak hold is to monitor a dead band for activity while you are away from the operating position. If you glance at the display every now and then you can see if any signals have appeared in the meantime. Peak hold is also useful to see the shape of a modulation spectrum. Since the sidebands are continually changing with modulation, the peak is a better indication of the spectrum than the instantaneous value.

Span

Adjusting the span is yet another way to make weak signals more visible. As you narrow the span, there is less noise within the range of each frequency display point. That reduces the apparent noise level while the signal levels stay the same, which increases the signal-to-noise ratio. At narrow spans, signals that are difficult or impossible to hear become visible, especially on the waterfall.

As mentioned before, it is useful to keep the noise level right at the bottom of the display. The P3 can automatically keep the noise level constant as you adjust the span by setting the menu *MENU:SpanScale: REF LVL only*. If you would also like the level at the top of the screen to remain constant as you adjust the span, set *MENU:SpanScale: REF LVL & Scale*.

Fixed-tune mode

When the P3 is used with a K3 transceiver, the center frequency on the P3 screen normally follows along as you tune VFO A on the K3. This is called *tracking* mode. In this mode, the frequency displayed at the top center of the screen is the display center frequency, and the labels at the top left and right show the frequencies of the left and

right edges of the display, in terms of their offset from the center. Usually, the VFO A frequency is at the center of the P3 display unless you have offset it with the P3's **CENTER** control. The display can be re-centered at any time by holding the **CENTER** key while already in center-frequency mode, which can be accomplished by holding the **CENTER** control twice.

In *fixed-tune* mode the frequencies on the P3 display stay fixed as you tune VFO A. The VFO A cursor moves across the screen instead of always being at the same position, as it is in tracking mode. You can toggle between fixed-tune and tracking modes via MENU:FixTrack. Fixed-tune mode is only available with the K3 transceiver.

The three frequency labels at the top of the screen have different meanings than they do in tracking mode. The one at the center is always the VFO A frequency, even when it is not at the center of the display. The labels at the top left and right are the actual RF frequencies that correspond to the left and right edges of the display, rather than the frequency offsets from the center.

If you tune VFO A past the left or right edge of the screen, one of four things can happen depending on the MENU:FixMode selection. If the mode is set to "Full" then the center frequency jumps up or down one full screen width whenever you tune past an edge so as to keep the VFO A cursor on the screen. If the mode is "Half", the center frequency jumps one-half screen width. In "Slide" mode, it moves the minimum amount necessary to keep the cursor on the screen. In "Static" mode, the center frequency is truly fixed; the VFO A cursor is allowed to disappear off-screen. In both tracking and fixed-tune modes, whenever either the VFO A or VFO B cursor is tuned off-screen, a small arrow at the bottom left or right of the display points in the direction of the missing cursor. The arrow color matches the cursor color.

When you switch between tracking and fixed-tune mode, the span stays the same. The center frequency also stays the same when switching from tracking to fixed-tune mode, but defaults to the VFO A frequency when going from fixed-tune to tracking mode. In either mode, the center frequency and span can be adjusted using the **CENTER** and **SPAN** keys (unless the **CENTER** key has been disabled for tracking mode with MENU:CenterEn).

The selection of fixed-tune or tracking mode is global, that is, it is the same on all bands and it is remembered when cycling power. In fixed-tune mode, the center frequency and span are stored in non-volatile memory per band. When changing bands or when turning on power, the last values used on that band are remembered, unless that would put the VFO A cursor off-screen, in which case the display is re-centered on VFO A. The only exception is Static mode, where the only way to change the center frequency or span while fixed-tune mode is in effect is to adjust the **CENTER** or **SPAN** keys.

Typical Spectra

Below is a typical screen shot of the 40 meter band during the day. At the center is a weak CW signal that was inaudible on the K3 transceiver during fades. It is hard to see on the spectrum display at the top but is clearly visible on the waterfall. Just to the right of that is a strong interfering carrier. At the far right is another steady carrier and just to the left of that is a spurious emission, probably from a switching power supply, that is wavering back and forth in frequency. A panadapter is a powerful tool for tracking down interference.

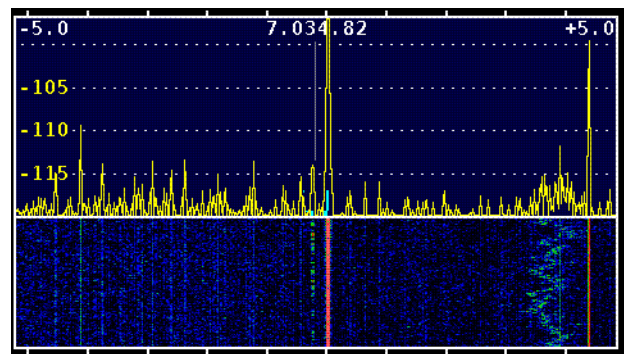

This is another example of interference, this time from a LAN router. The QRM includes both wideband noise as well as discrete carriers and is constantly heaving and writhing as the processor in the router executes different portions of its software routines.

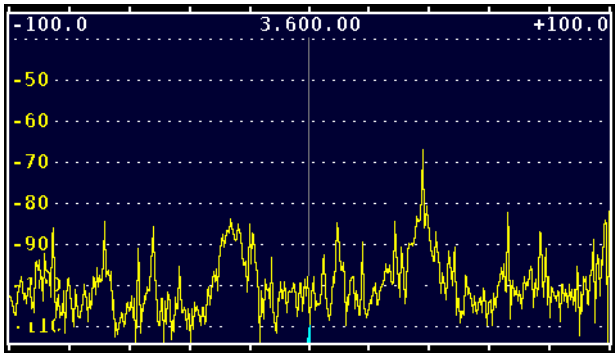

Spurious signals generated in the transceiver are sometimes visible as well. As you tune the transceiver you may see carriers that scroll across the screen much faster than other signals, sometimes tuning in the opposite direction. These are created by high-order harmonics of the VFO, BFO and other signal sources in the transceiver. Normally you won't hear them in the receiver unless one falls within the I.F. passband, but they are easy to see on the panadapter display because of its much wider bandwidth.

This is a shot of a local AM broadcast station, illustrating the use of peak hold to show the shape of the modulation spectrum, which extends to plus and minus 10 kHz from the carrier and then drops off abruptly to meet FCC regulations.

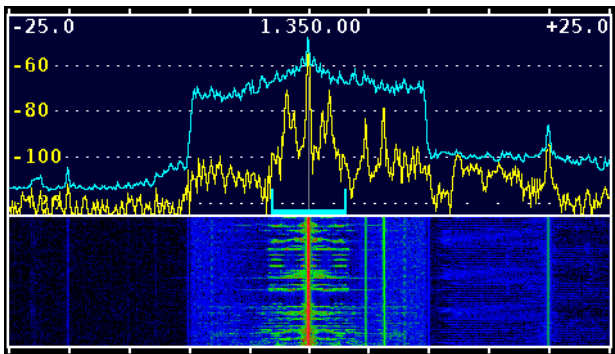

Normally the P3 display is frozen while the K3 is transmitting. However if you temporarily disconnect the RS232 cable between the P3 and K3, that function is disabled and it is possible to view your own transmissions for test purposes. The signal level is rather weak as it depends on random leakage in the K3's I.F. chain, so you may need to experiment with **REF LVL** on the P3 and the power level and frequency band on the K3 to get an adequate signal. Also, the frequency may not be exactly centered on the display due to the effect of crystal filter offsets in the K3.

The following image shows a typical LSB spectrum obtained in this way. Peak hold is enabled in order to get a better view of the spectrum shape. Notice that the low audio frequencies (on the right) are much stronger than the high audio frequencies. A flatter spectrum is considered desirable to improve the signal's "punch" in the presence of noise and interference, especially when speech compression is used. The P3 is a handy tool for adjusting the transmit equalizer in the K3.

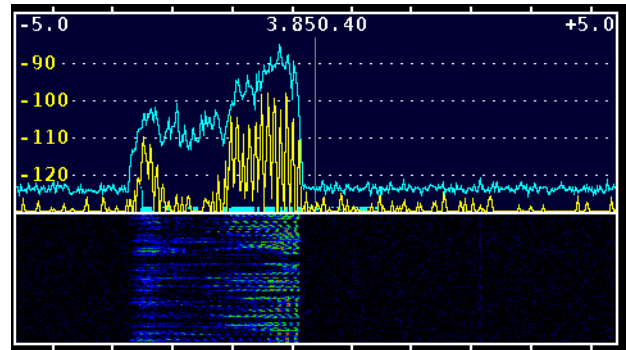

The previous image also illustrates an important point when using markers. On SSB, the frequency that is shown on the display of the K3 transceiver is the suppressed carrier frequency. When you QSY the transceiver using MKR A or MKR B on the P3, that is the frequency the K3 will go to. So on bands where LSB is used, you should place the marker just above the spectrum of the SSB signal you are trying to net (approximately in the center of the above display) and for USB, place the marker just below the spectrum.

Advanced Operating Features

Use with Other Radios

The P3 can be used with any receiver or transceiver that has means to output an intermediate-frequency (I.F.) signal between approximately 455 kHz and 21.7 MHz. Frequencies a little beyond that range can be used at reduced sensitivity.

The I.F. may be selected via *MENU: Xcvr Sel*. If you are not sure what frequency is used by your receiver, apply a test signal to the receiver antenna and scroll through the menu list until you see the signal on the display. Many receivers use an inverted I.F., meaning that signals tune in the opposite direction, so many of the selections include that feature. As you tune the receiver upwards in frequency the signal should move to the left on the display.

If the correct I.F. is not in the list, the frequency of the *USER* selection may be set manually via *MENU: Xcvr Def*.

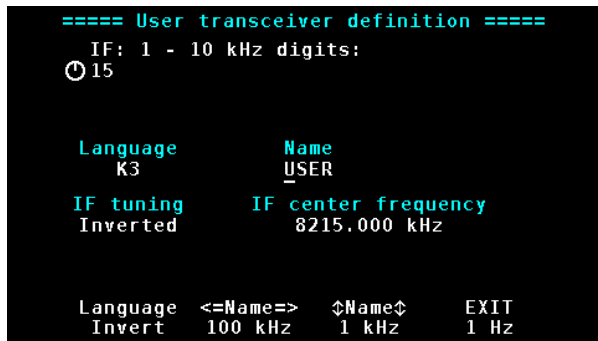

Xcvr Def Display.

Xcvr Def also allows you to select between inverted and non-inverted I.F., change the name "USER" to something else, and select the programming language (currently either None or K3).

The *Xcvr Def* function temporarily re-defines the function (FN) keys with legends across the bottom of the display as shown above. There are three keys to set the frequency in 100 kHz, 1 kHz or 1 Hz steps.

The FN2 and FN3 keys are used for changing the transceiver name. The one with the horizontal arrows selects the character position as you rotate the **SELECT** knob and the one with the vertical arrows selects a character from a list by rotating the knob.

Tap **FN4** (EXIT) to return the P3 to normal operation.

Use with Transverters

The I.F. output of many transceivers tunes backwards. For example, the K3's I.F. output is inverted on all bands except 50 MHz. The P3 takes this into account automatically. However, if you are using an external transverter, the tuning direction depends upon whether the band it converts down to is the 50 MHz band (not inverted) or some other band (inverted).

To configure the P3 so the displays moves as expected regardless of the tuning direction, select *MENU:XV Invert*, tap the **SELECT** knob, and adjust the knob to select the desired transverter band: 1-9. Tap the knob again to select either "Inverted" or "Not Inverted".

See also *Amplitude Calibration for Transverters* on pg 26. If you are using your P3 with an Elecraft K3, the K3 Owner's manual contains more information about working with transverters.

Remote-Control Commands

Many P3 functions may be accessed by remote-control commands sent via RS232. These commands use ordinary ASCII text, so they can be tested using a terminal emulator or the Command Tester tab in P3 Utility. When the P3's XCVR RS232 port is connected to a K3, then both P3 and K3 commands may be sent and received via the PC RS232 port.

To distinguish them from K3 commands, P3 commands begin with the "#" symbol. For example, "#RVM;" returns the P3 firmware revision and "RVM;" returns the K3 main firmware revision. P3 remote-control commands are fully described in the *P3 Programmer's Reference*.

P3 Utility Program

In addition to downloading firmware (pg 23) the P3 Utility can perform several other functions. For example, it can upload a bitmap image of the P3 display which can be saved to a file or pasted into a graphics program on the computer. Refer to the Help menu in P3 Utility for more information.

Firmware Upgrades

New features and improvements are available to all P3 owners via firmware upgrades.

Please visit the Elecraft K3 software page (www.elecraft.com) to obtain our free firmware download application, *P3 Utility*. Versions of the Utility program are provided for PCs, Macs, and Linux platforms.

⚠ Some applications or peripheral devices may interfere with P3 downloads; check the Help information in *P3 Utility* if you have difficulty.

If you don't have Internet access, you can obtain a firmware upgrade on CD. If you don't have a computer, you can send your P3 to Elecraft to be upgraded. See Customer Service, pg. 9.

Checking your Firmware Revision

Use the MENU entry *FW Rev* to determine your firmware revision.

P3 Firmware Self-Test

The P3 checks for firmware errors at turn-on. If an error occurs, the P3 Boot Loader is started automatically. Connect the P3 to your computer and reload firmware.

Forcing a Firmware Download

If you accidentally load an old or incompatible firmware version and find the P3 unresponsive, do the following: (1) Disconnect the P3 from the power supply and wait 5 seconds; (2) connect the power supply again while holding the P3's POWER switch in; after about 10 seconds you'll see the Boot Loader screen; (3) load the correct firmware version.

Updating K3 Firmware

If you have the P3 XCVR port connected to the K3 RS232 port, you can update your K3 firmware without disconnecting the RS232 cables to the P3. The K3 utility program automatically puts the P3 into a special pass-through mode until downloading the K3 firmware is complete. If an older version of P3 firmware is installed that does not support this mode (00.36 or earlier) then the K3 Utility will prompt you to turn off the P3 before beginning the download. Turning the P3 off automatically bypasses the P3 so there is a direct connection between the computer and the K3. If you have configured the P3 so you cannot turn it off with the **POWER** switch (see *Configuration* on page 24), unplug the power connector on the P3's rear panel. Leave the P3 off until the download is finished.

K3 MCU LD Error

If you accidentally cycle power on the K3 or P3 while downloading firmware to the K3, the K3 may become unresponsive in bootstrap mode (MCU LD displayed on the K3's LCD). Clear the condition as follows:

- Turn the P3 off.
- If the P3 is configured to turn on automatically when power is applied to the K3, disconnect power from the P3's rear panel. It's important that the P3 remain off throughout the procedure.
- Disconnect power from the K3's rear panel.
- Exit the K3 Utility program at your computer.
- Reconnect power to the K3's rear panel and turn the K3 on. Be sure the P3 does not come on with the K3. If it did, repeat the procedure from the beginning and be sure to unplug the P3's power cable. It won't work to turn the P3 off once it has turned on.
- Restart the K3 Utility at your computer, and reload the firmware.

Configuration

The front panel **POWER** switch may be bypassed so the P3 turns on when power is applied. This is useful to turn the P3 on automatically when it is powered from the auxiliary jack on a transceiver such as the Elecraft K3 so the P3 turns on with the transceiver.

To configure the power control, remove the six flat head screws holding the P3 top cover and lift it off. A small slot is provided in the cover so you can use a fingernail to lift it. The I/O board at the back of the P3 has a jumper at the top corner farthest from the rear panel above the large ribbon cable connector (see below).

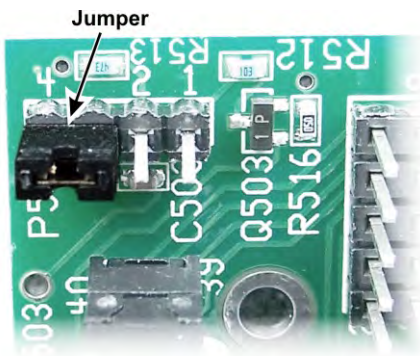

The jumper may be positioned on the pins as follows:

Pins 3 & 4: Normal operation of the **POWER** switch.

Pins 2 & 3: P3 turns on automatically when power is applied to the rear panel connector. P3 may be turned off and on using the **POWER** switch as long as power is applied.

Pins 1 & 2: **POWER** switch is disabled. P3 turns on automatically and remains on as long as power is applied to the rear panel connector.

Even if bypassed so power is on all the time, the **POWER** switch is still used in the event it is necessary to put the P3 in Boot Loader mode to force a firmware download. To cancel Boot Loader mode, remove power from the P3.

Calibration Procedures

Frequency Calibration

The P3 requires no calibration for normal panadapter operation. However if additional frequency accuracy is desired, you can perform the following calibration procedure.

⚠ Turn the transceiver and P3 on and allow them to warm up for 30 minutes, minimum, before performing the calibration.

- If the transceiver has a calibration procedure to correct its frequency errors, perform that procedure first.
- Using a well-calibrated signal generator or an on-the air carrier signal of known frequency, tune in the signal on the transceiver. An A.M. broadcast station can serve as a suitable test signal.
- Adjust the transceiver frequency to the known frequency of the test signal. Depending upon the modulation mode of the transceiver, the signal may not be audible.
- Set the P3 to tracking mode via MENU:FixTrack, set the span to minimum, and adjust the reference level and scale so you can easily see the signal.
- Hold **CENTER** twice to remove any center frequency offset that may have been introduced.
- Select *MENU:Ref Cal*, tap the **SELECT** knob, and adjust the frequency calibration until the carrier is centered horizontally on the display. If the required correction is more than a few hundred units, it may be that the I.F. frequency is set incorrectly. That can be adjusted via *MENU:Xcvr Def*.

Amplitude Calibration

The P3 comes with a default amplitude calibration that works well with a K3 transceiver. Note: If your K3 was manufactured before September 2009, it must have the “I.F. Output Buffer Gain Modification” for the default value to be accurate (see the note at the top of page 5).

If you have an older K3 without the modification or you are using another type of transceiver, or if you'd simply like to optimize the calibration, you can perform the following calibration procedure.

You will need a signal generator with a calibrated output level. The recommended frequency is 7040 kHz with an output level of 50 microvolts (-73 dBm). The Elecraft XG2 signal generator will provide the recommended output and frequency.

Other power levels and frequencies within range of your transceiver may be used. You'll need to make suitable adjustments to the frequencies and levels given in the following procedure.

- Connect the P3 IF IN to the transceiver's i.f. output.
- If using a K3, connect the RS232 cable between the K3 and P3, turn the preamplifier OFF, the attenuator ON and be sure the sub receiver is not enabled.
- Connect the signal generator to the transceiver antenna input. If using a K3 with the KXV3 option, it is best to use the RX ANT IN connector to eliminate the possibility of damaging your signal generator if you accidentally put the K3 in transmit. If you use the main antenna connector and have the KAT3 option installed, put it in bypass by holding **ATU** until BYPASS appears on the LCD display.
- Set the signal generator for 7040 kHz at a signal level of 50µV (-73 dBm).
- Put the P3 in tracking mode via MENU:FixTrack, set the span to 100 kHz, and tune the transceiver to approximately 7015 kHz so the signal is centered on the right half of the display.
- Set the P3 Scale to maximum expansion (10 dB) and adjust the Ref Lvl to about -78 dBm in order to place the signal peak about half way up the screen. You may notice a slight variation in the peak signal level with small adjustments in the transceiver frequency as the signal moves from pixel to pixel on the screen. Adjust the frequency for maximum reading.

- Select *MENU:Lvl Cal*, tap the **SELECT** knob, and adjust the knob to place the signal peak at -73 dBm on the display. Note: the K3's RX ANT input has about 1 dB less loss than the ANT connector, so you may want to set the signal level at -72 dBm when using that input.



Amplitude Calibration for Transverters



You can calibrate a receiving or transmitting converter, either the K3's internal K144XV or an external device connected to the K3.



If you plan to do the above calibration on an HF frequency, do that first since that calibration will affect the transverter calibration.

- Set up the P3, the signal generator, the transverter and the K3 in the manner described above to obtain a signal in the center of the right-hand side of the display and with its peak centered vertically.
- Select *MENU:XV Gain*, tap the **SELECT** knob, and adjust the knob to select the desired transverter band: 1-9. (You can enter separate calibration values for each transverter band by repeating this procedure for each band.)
- Tap the **SELECT** knob again, and adjust the knob to place the signal peak at the level corresponding to the output of your signal generator.

Menu Functions

Tap **MENU** and then turn the  **SELECT** knob to scroll through the following list of menu functions. Tap the  **SELECT** knob to select the displayed function.

Entry	Default	Description
CenterEn	OFF	When OFF, the CENTER key does not adjust the center frequency when in tracking mode.
Cursors	Bar	Bar produces a full height translucent bar on the spectrum display. "U" produces a U-shaped cursor at the bottom of the spectrum display.
DispTest	off	Shows a test pattern with a color bar and the complete character set of each font. Tap MENU to exit.
FixMode	Half	Select what happens when the K3 VFO A is tuned off-screen in fixed-tune mode. "Full" or "Half" means automatically adjust the center frequency by one full screen or one half screen to keep VFO A within range. "Slide" means move the center frequency the minimum amount. "Static" means don't move the center frequency at all, that is, allow the cursor to move off screen.
FixTrack	Tracking mode	Toggle between fixed-tune mode and tracking mode.
Font	9 x 14	Changes the font size.
FN Erase	N/A	Resets a function key to its un-programmed state. Tap or hold the function key to be erased while this menu item is displayed.
Freeze	off	Freezes or un-freezes the current spectrum and waterfall display. This function is most useful when assigned to a function key, which toggles between the frozen and un-frozen state.
FW Rev	N/A	Displays the main firmware version number. It is not necessary to tap the  SELECT knob for this function.
Knob Tap	N/A	When assigned to a function key, duplicates the  SELECT knob's tap function.
Knob Hold	N/A	When assigned to a function key, duplicates the  SELECT knob's hold function.
LCD Brt	100	Adjusts the display brightness from 0-100.
LCD Test	off	Set all display pixels to white at full brightness.
Lvl Cal	-5.8	Calibrates the "transfer gain" (gain from antenna to IF OUT connector) of the transceiver (see pg 24).
Lvl Lines	Dotted	Select the amplitude level graticule line type, dotted or solid.
Lvl Mode	dBm	Select the amplitude level display units, either dBm or S-units plus dB over S9.
MKRA zero	N/A	Resets marker A to the center of the screen.
MKRB zero	N/A	Resets marker B to the center of the screen.
Peak	off	Toggles peak-hold mode on and off. This function is most useful when assigned to a function key.
Rate	10	Changes the display update rate in milliseconds. Although values down to zero may be entered, the minimum display period is actually limited by hardware.
Ref Cal	0	Calibrates the 60 MHz P3 reference clock frequency (Pg 24).
Reset	N/A	Resets the P3.

Entry	Default	Description
RS232	38400	Change the baud rate in bits per second of the serial port that connects to a host computer. During firmware download (via the P3 Utility program), the baud rate is set automatically to 38400 baud, but it is then restored to the value selected in this menu entry.
SpanScale	REF LVL only	Specifies the way the P3 responds to changes in SPAN. "Off" means do not change REF_LVL or SCALE when SPAN is changed. "REF LVL only" means change the reference level to keep the noise level approximately constant. "REF LVL & SCALE" means also change SCALE to keep the level corresponding to the top of the screen at a constant level as well.
Span Set	N/A	Tap or hold a function key to assign a current SPAN to that key. Once assigned the function key can be used to set the span with a single key press. The key label shows the span in kHz.
Sw Test	off	Toggle switch test mode on or off. When on, a special test screen is displayed that shows the state of each switch and the current encoder count. Tap the  SELECT knob twice to exit.
VFO B	on	Turns the VFO B cursor on or off.
Waterfall	100	Changes the height of the waterfall window when the display is in waterfall mode.
Wfall Avg	off	Enables or disables application of averaging to the waterfall display
WfallMkrs	off	Enables or disables markers on the waterfall display.
Xcvr Def	off	This key brings up a menu to define the "User" transceiver in the transceiver selection menu, Xcvr Sel. You can change the intermediate frequency (I.F.), the I.F. tuning direction (inverted or not), the transceiver's command language, and the transceiver name.
Xcvr Sel	K3	Allows changing among a list of transceivers. For transceivers not listed, it also allows selecting a user-defined transceiver or simply choosing the I.F.
XV Gain	+25.0	Calibrate the gain of the transceiving converters (transverters) used with the K3 (see pg 25). Stores separate values for each of the 9 transverter bands.
XV Invert	Inverted	Specify the tuning direction of the intermediate frequency bands used for transceiving converters. First select one of the 9 transverter bands, and then tap the  SELECT knob to choose "Inverted" or "Not Inverted" (see pg 22).
CenterEn	OFF	When OFF, the CENTER key does not adjust the center frequency when in tracking mode.
DispTest	off	Shows a test pattern with a color bar and the complete character set of each font. Tap MENU to exit.
FixMode	Half	Select what happens when the K3 VFO A is tuned off-screen in fixed-tune mode. "Full" or "Half" means automatically adjust the center frequency by one full screen or one half screen to keep VFO A within range. "Slide" means move the center frequency the minimum amount. "Static" means don't move the center frequency at all, that is, allow the cursor to move off screen.

Troubleshooting

The most common symptoms and their causes are listed below.

Can't turn power off. The most likely cause is the power turn-on jumper located on I/O board is set incorrectly. See *Configuration* on page 24.

"FAILED CHECKSUM" message appears in the "P3 BOOT LOADER" screen. Main P3 firmware is not present or corrupted. Use P3 Utility to download new firmware. (Pg.23).

"DOWNLOAD FIRMWARE, READY FOR DOWNLOAD" message appears in the "P3 BOOT LOADER" screen. Either cycle power to return to normal operation or use P3 Utility to download new firmware (Pg. 23).

Center frequency shows zero Hertz. This is normal if the transceiver is not connected to the P3's RS232 port. If the transceiver is a K3 that is connected via RS232, check for a loose or defective serial cable.

P3 displays the wrong center frequency. Hold the **CENTER** key to select the center frequency adjustment and then hold it again to re-tune the P3 center frequency to the K3 VFO A frequency.

Amplitude display is in error by about 3 dB. Check that the rear-panel IF OUT switch is in the correct position.

Intermittent clicking sound heard. The P3 includes a relay that automatically bypasses the input amplifier when very strong signals overload the front end. Try turning off the transceiver's preamplifier or turning on its attenuator.

Parameter Initialization

Menu parameters are stored in non-volatile EEPROM memory. It is possible, though rare, for parameters to become altered in such a way as to prevent the firmware from running correctly. If you suspect this, you can reinitialize parameters to defaults.

i Reinitializing the parameters will erase any Function key assignments you have made and return all of the MENU entries to the default values shown in pg 26.

- Write down your function (FN) key assignments and MENU parameters you have set.
- Turn the P3 OFF (tap the P3's **POWER** switch, not by turning off your power supply). If the power-on jumper on the I/O board is in the "always-on" position (pg 24), then skip this step.
- While holding in the **LABELS** key, tap the **POWER** switch to turn the P3 on. After about 2 seconds, let go of the **LABELS** key. You should now see **CONFIGURATION RESET** on the LCD screen.
- Re-enter all the menu parameters and function key assignments you wrote down.
- See if the original problem has been resolved.

Theory of Operation

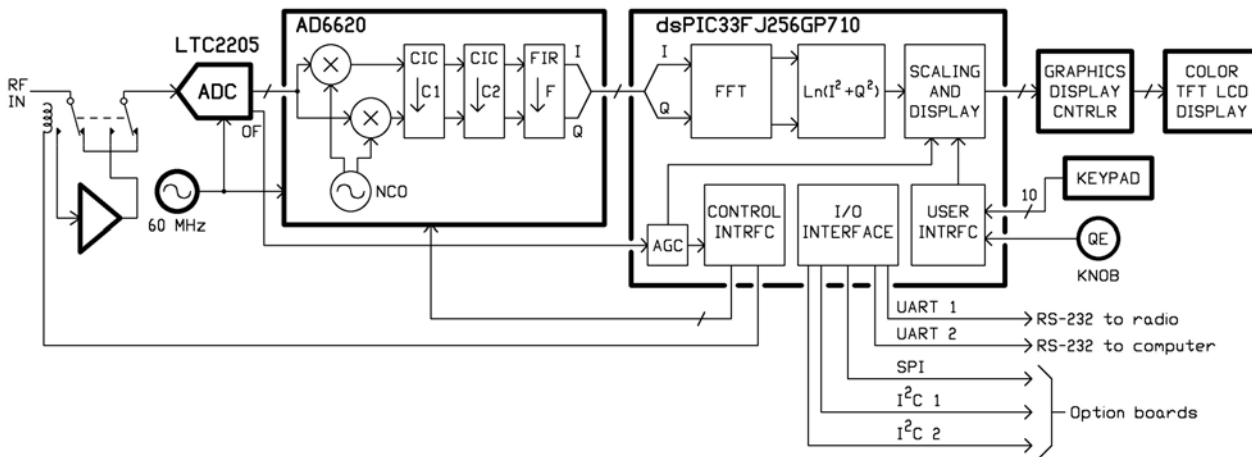

The P3 is a true software-defined receiver — the input goes through an amplifier directly to a 60 Msample/sec analog-to-digital converter (ADC), with all tuning, signal processing and the user interface under software control. The Analog Devices AD6620 digital down-converter includes a numerically-controlled oscillator (NCO) which acts as a local oscillator and a pair of multipliers that act as a quadrature mixer that down-convert a band of frequencies to a pair of baseband in-phase and quadrature (I/Q) signals. Those signals then pass through three decimating low-pass filters to generate a lower-bandwidth, lower-sample-rate I/Q signal that is passed to a Microchip dsPIC digital signal processor/controller.

The dsPIC further processes the signal for presentation on the 480x272-pixel color TFT LCD display. The "circuitry" shown inside the processor box in the block diagram is actually implemented as software routines. The FFT is the fast Fourier transform, which is a software version of a hardware spectrum analyzer. It reads the incoming signal and calculates the frequency spectrum. Further software routines calculate the power of the spectrum, take the logarithm, and then scale and offset the result so that it reads correctly in dBm on the display.

The dsPIC also acts as a controller for the rest of the circuitry. For example, whenever the user changes the span, new decimation and filter values are calculated and loaded into the AD6620 digital down-converter and new constants are calculated for interpolating the FFT output for display. In that way, the optimum sample rate is used for any span, which optimizes the display update speed and ensures that each horizontal pixel on the display always represents a distinct frequency, with minimum bleed-over between pixels.

One firmware task is to maintain communications with the K3 transceiver over one of the RS232 ports. A special P3-specific command set has been implemented in the K3 to maximize communications efficiency. In addition, a special P3-K3 communications protocol was set up to ensure that the P3 gets the information it needs when it needs it, so that the P3 acts as a fully-integrated extension of the K3.

In addition to two UART (universal asynchronous receiver-transmitter) ports for the two RS232 connectors, an SPI (serial peripheral interface) and two I²C (inter-integrated circuit) interfaces are provided for option modules. Those interfaces, plus power supplies and other signals, are carried on a 40-wire ribbon cable between the main front-panel processor board and the rear-panel I/O board. Option boards are stacked on the I/O board, with the 40-pin connectors daisy-chained together, acting like a bus or backplane. In that way, more options may be included in the future simply by stacking more boards.

For best efficiency, the +3.3 V and +5 V internal power supplies are supplied by a pair of switching DC-DC converters from the +12 VDC input. The input power is approximately independent of the voltage, which means the lower the input voltage the higher the current. While the P3 will typically work with input voltages of less than 8 V, the current may exceed the 0.5 A specification at that voltage.

Parts List



P3 Sheet Metal Box - E850435

In addition to the components below, this box contains this manual and the K3 I.F. Buffer Gain Modification kit consisting of an instruction sheet with a small envelope containing resistors attached. This kit should be installed on *some* K3's for optimal P3 performance. See page 5 for details.

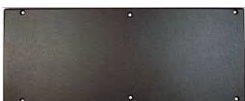
P3 Side Panel Assembly – E850428

ILLUSTRATION	DESCRIPTION	QTY.	ELECRAFT PART NO.
	Side Panel	2	E100361



P3 Cover Assembly – E850429

ILLUSTRATION	DESCRIPTION	QTY.	ELECRAFT PART NO.
	Top Cover	1	E100362
	Bottom Cover	1	E100363

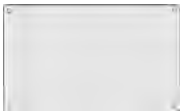
P3 Front Panel Assembly E850430

ILLUSTRATION	DESCRIPTION	QTY.	ELECRAFT PART NO.
	Front Panel	1	E100364
	Display Bezel	1	E100354

P3 Rear Panel Assembly – E850431

ILLUSTRATION	DESCRIPTION	QTY.	ELECRAFT PART NO.
	Rear Panel	1	E100365
	Hole Cover	1	E100396

P3 Misc Bag - E850433

P3 Chassis Hardware – E850409













ILLUSTRATION	DESCRIPTION	QTY.	ELECRAFT PART NO.
	2-D Fastener	8	E100078
	L-Bracket	4	E700073
	Jackscrew Nut, 4-40	4	E700078
	Screw, Pan Head, Zinc, 4-40 7/16" (11 mm)	6	E700032
	Nut, Hex, 4-40	6	E700011
	Lock Washer, Inside Tooth, #4	10	E700010
	Screw, Pan Head, Black, 4-40 3/16" (4.8 mm)	10	E700015
	Screw, Flat Head, Black 3/16" (4.8 mm),	22	E700025
	Lock Washer, BNC, Inside Tooth 9/16" (14.3 mm)	4	E850433
	Nut, BNC, 9/16" (14.3 mm)	2	E700059
	Tilt Stand with Front and Rear Feet	1 set	E980129
Continued on next page			

ILLUSTRATION	DESCRIPTION	QTY.	ELECRAFT PART NO.
	Knob	1	E980089

P3 Front Panel Hardware Envelope – E850432

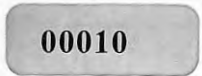



ILLUSTRATION	DESCRIPTION	QTY.	ELECRAFT PART NO.
	Screw, Black, Pan Head, 2-56 1/4" (6.4 mm)	8	E700124
	Threaded Standoff, 2-56 5/16" (8 mm)	4	E700122
	Lock Washer, Split Ring, #2	8	E700123

P3 Cables – E850434

ILLUSTRATION	DESCRIPTION	QTY.	ELECRAFT PART NO.
	Power Cable 2.1 mm Barrel – RCA	1	E850427
	Ribbon Cable, 40 cond. 36" (91.5 cm)	1	E850438
	RF Cable, BNC – BNC, 36" (91.5 cm)	1	E980170
	TMP Cable, 10" (25.4 cm)	1	E850338
	DE9 Cable M-F, 36" (91.5 cm)	1	E980169

Note: Some cables may have packages showing the original vendor's part number instead of the Elecraft part number.

P3 PCB Box – E850436

ILLUSTRATION	DESCRIPTION	QTY.	ELECRAFT PART NO.
	Serial Number Label (in protective envelope)	1	E850437
	P3 Front Panel Board with LCD and Switch Matrix. ⚠ IMPORTANT: Components on this board are easily damaged with careless handling. Leave it in its protective wrapping until instructed to remove it. One pin has been cut on the 40-pin connector. This is intentional.	1	E850426
	P3 Rear Panel I/O Board. Note that one pin has been removed from the 40-pin connector. This is intentional.	1	E850386
	Header Shorting block, 2 pin (supplied mounted on the Rear Panel I/O board.)	1	E620055
	P3 Rear Panel RF Board	1	E850396

Kit Assembly Instructions

Preventing Electrostatic Discharge Damage

Sensitive components in your P3 are may be damaged by Electrostatic Discharge (ESD) in any location or climate unless you take specific steps to prevent such damage. Many components can be damaged by static discharges of only a few volts: far too little for you to notice.

ESD damage may not be apparent at first. The damaged components may not fail completely. Instead, the damage may result in below-normal performance for an extended period of time before you experience a total failure.

We strongly recommend you take the following anti-static precautions (listed in order of importance) to ensure there is no voltage difference between the components and any object that touches them:

- Leave ESD-sensitive parts in their anti-static packaging until you install them. The packaging may be a special plastic bag that allow static charges to flow harmlessly over their surface, or the component's leads may be inserted in conductive foam that keep them at the same potential. Parts which are especially ESD-sensitive are identified in the parts list and in the assembly procedures.
- Wear a conductive wrist strap with a series 1-megohm resistor that will constantly drain off any static charge that accumulates on your body. If you do not have a wrist strap, touch a ground briefly before touching any sensitive parts to discharge your body. Do this frequently while you are working. You can collect a destructive static charge on your body just sitting at the work bench.

WARNING

DO NOT attach a ground directly to yourself without a current-limiting resistor as this poses a serious shock hazard. A wrist strap must include a 1-megohm resistor to limit the current flow. If you choose to touch an unpainted, metal ground to discharge yourself, do it only when you are not touching any live circuits with any part of your body.

- Use a grounded anti-static mat on your work bench.
- If you choose to use a soldering iron to work on your P3 for any reason, be sure your iron has an ESD-safe grounded tip tied to the same common ground used by your mat or wrist strap.

Tools Required

1. #0 and #1 size Phillips screwdrivers. Use the screwdriver that best fits the screw in each step. To avoid damaging screws and nuts, a power screwdriver is *not* recommended.
2. Needle-nose pliers.

The following tools are strongly recommended:

1. ESD wrist strap.
2. Static dissipating work pad.

Assembly Procedure

Overview of the Kit

The circuit boards are mounted on the front and rear panels and interconnected by cables as shown in Figure 1. The enclosure uses Elecraft's 2D fasteners at the corners of the panels which allow removing any combination of panels to gain access to the interior.

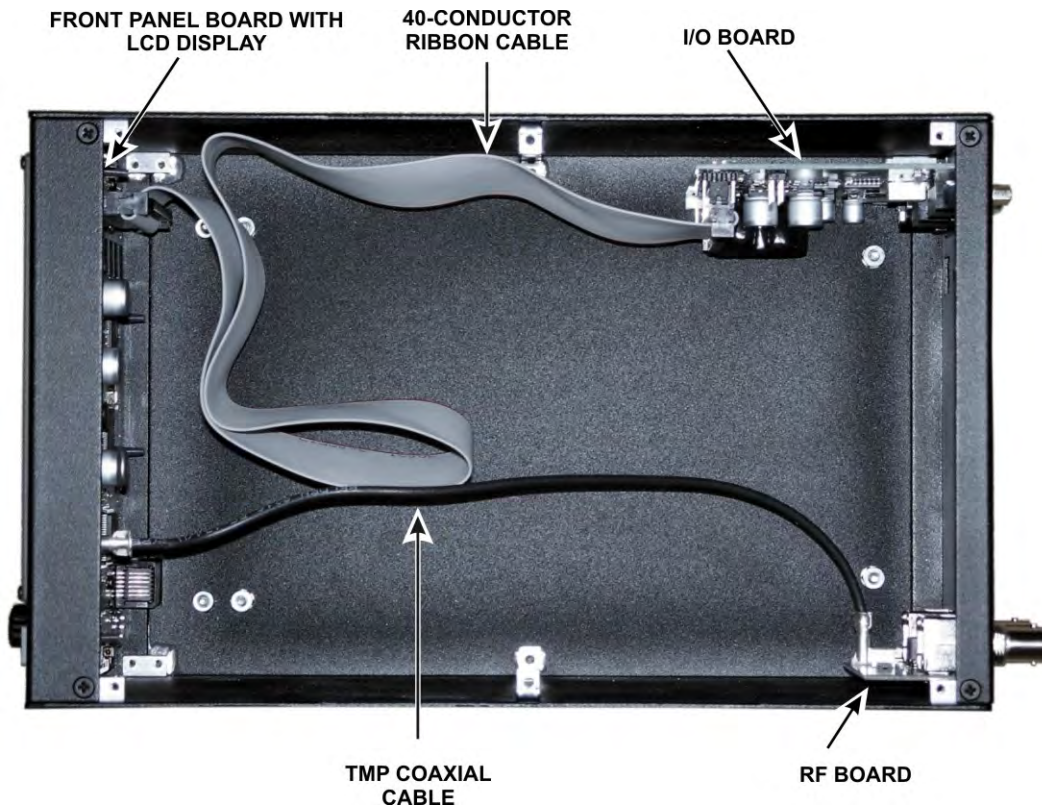

Figure 1 Assembled P3 with Top Cover Removed.

Before starting construction, do a complete inventory, comparing the parts in your kit with the parts list beginning on 30, to familiarize yourself with all of the parts and to ensure the kit is complete, **but do not unwrap the front panel display board until instructed to do so in the assembly procedure.** If any parts are missing, contact Elecraft for a replacement (see, *Customer Service and Support* on page 9). Recommend you also keep the printed circuit board assemblies in their anti-static packaging until you are instructed to remove them.

Front Panel Assembly

⚠ CAUTION: The PC Boards are ESD-sensitive. Wear an ESD-safe wrist strap or touch a metallic ground regularly while handling the boards or at any time while working inside the P3. See *Preventing Electrostatic Discharge Damage* on page 34 for more information.

☐ Carefully remove the front panel display board from its anti-static packaging, taking care not to damage the transformers or other components (Figure 2) or to allow the display panel to fall out of the soft rubber switch matrix (Figure 3). You may notice that one of the pins on 40-pin connector P200 has been cut off. That is intentional.

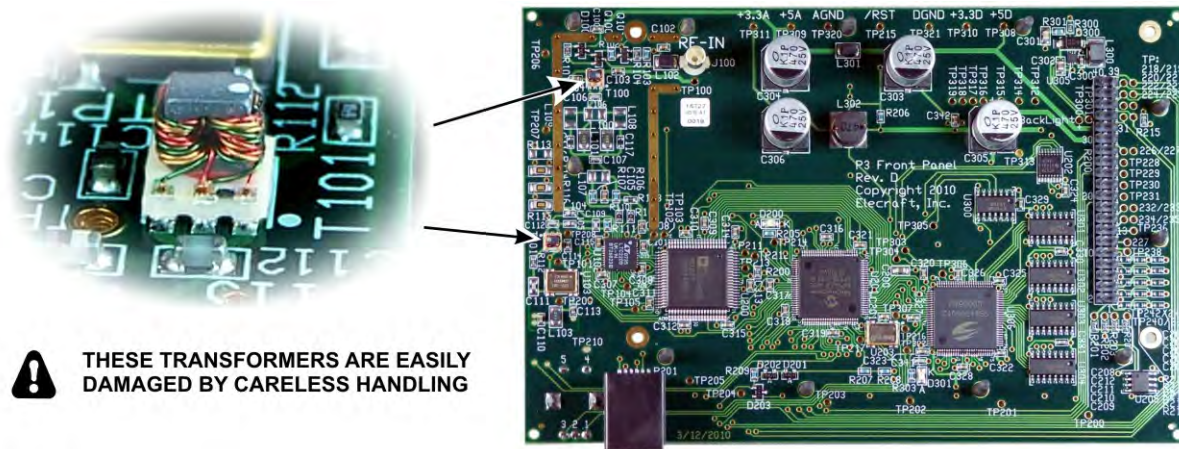

Figure 2. Front Panel Display Board Component Side.

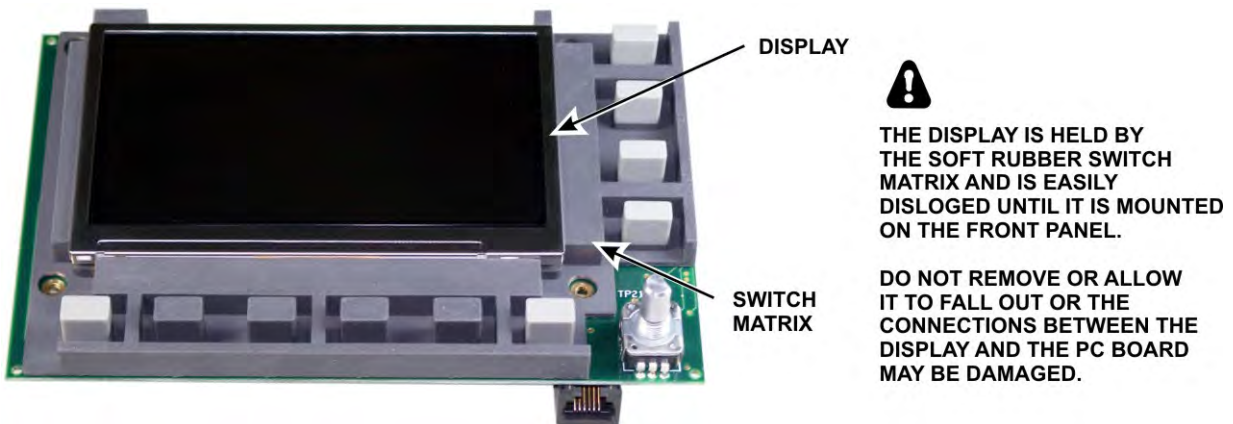

Figure 3. Display Panel in Front Panel Board.

☐ Inspect the display panel to ensure it is seated flat in the matrix as shown. Press it gently in place as needed but avoid touching the black surface and leaving fingerprints. Take care not to pull the display free as you may damage the connections to the printed circuit board behind it. If you ever need to remove the display panel from the board, refer to *Replacing the LCD Display* on page 47 for detailed instructions.

Mount four 2-56 5/16" (7.9 mm) standoffs on the front panel display board as shown in Figure 4. Be sure to place one lock washer between the standoff and the pc board as shown. This lock washer is important to establish the proper height of the standoff.

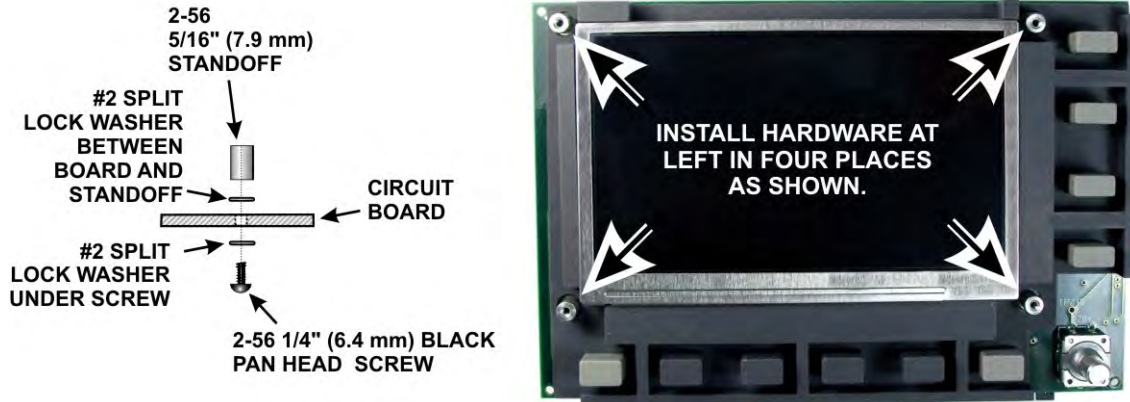

Figure 4. Mounting Standoffs on Front Panel Board.

Locate the front panel. There are holes at each corner of the top and bottom flange and four holes around the opening for the display. The inside surface of the panel was masked during painting to ensure a small area of clean metal around each hole. Check each hole to ensure there was no tape left and the metal is clean and visible. This is important to ensure good grounding between the panels making up the cabinet.

Remove the plastic display bezel from its protective wrapping and inspect it for dirt and dust, especially on the flat side that will face the display panel. Use a soft cloth if necessary to remove any objects clinging to the plastic. Similarly, inspect and clean the face of the display. If either requires further cleaning see *Cleaning the LCD Bezel* on page 46.

Look closely at the edge of the bezel and note that the edge is slightly beveled on one side. This side will face away from the front panel.

☐ Position the display board behind the front panel so all four standoffs line up with the holes in the panel. Be sure the buttons all pass through their respective holes in the panel. Place the plastic bezel over the display so its holes line up. Be sure the flat side of the bezel is toward the front panel and the side with the beveled edges is facing away from the panel (see Figure 5). Secure the bezel with four 2-56 1/4" (6.4mm) black pan head screws. Do not use lock washers. **Do not over-tighten the screws. You can distort or break the bezel.**



Figure 5. Bezel Mounted on Front Panel.

☐ Check to ensure the knob has its spring insert in place, then press it onto the shaft. Be sure the flat on the shaft is aligned with the flat surface in the knob (see Figure 6). The control has a built-in switch so do not be surprised to hear a click when you press the knob onto the shaft. The knob will stand above the surface of the front panel to allow room for the knob to move when operating the switch. Also, some side-to-side movement of the knob is normal in a control of this type with a built in switch.

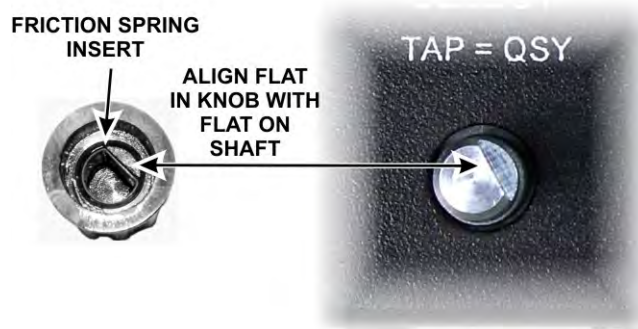

Figure 6. Installing the Knob.

Mount a 2D fastener at the top of the front panel assembly as shown in Figure 7. Do not use a lock washer. The 2D fasteners must always be oriented so the wide side of the fastener is toward the outside as shown. Tighten the fastener only enough to hold it in place. You will be loosening and adjusting all of the enclosure screws later as you finish the assembly and adjust the fit of all the panels.

⚠ IMPORTANT: All of the 2D fasteners must be installed with the widest shoulder toward the outside. The enclosure screws on the top and sides use flat head screws while those on the bottom use pan head (rounded top) screws.

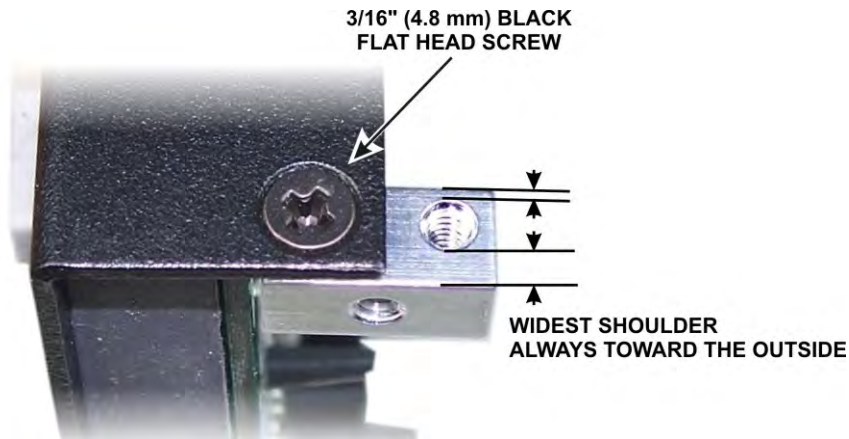

Figure 7. Installing 2D Fasteners.

Mount three more 2D fasteners on the front panel, one at each corner of the top and bottom flanges. Be sure to use pan (rounded) head screws in the bottom two holes.

Set the front panel assembly aside in a safe place.

Locate the top and bottom covers. Both covers have six holes for screws along the edges. The bottom cover has an additional six holes for the feet; four holes near the front end and two holes near the back. Also the bottom cover holes are *not* counter-sunk for flat-head screws.

At the back end of the bottom cover (with just two holes for feet) install a foot in each hole as shown in Figure 8. Be sure the feet are mounted on the bottom (fully-painted) side of the bottom cover.

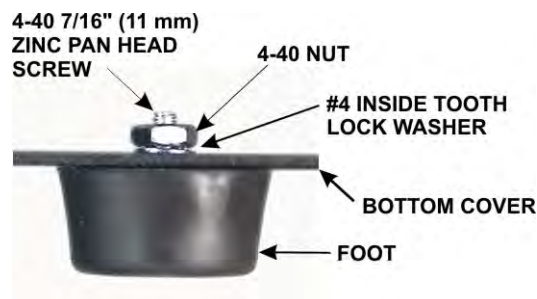

Figure 8. Installing Rear Feet.

At the front end of the bottom cover, install the two feet and tilt stand as shown in Figure 9. Place the tilt stand with the ends inserted into the holes in the feet as shown before attaching the feet to the bottom cover. Use 4-40 7/16" (11 mm) zinc pan head screws with inside tooth lock washers and nuts just as you did for the rear feet.



Figure 9. Installing the Tilt Stand.

At the mid-point along each side of the bottom and top covers is a screw hole. Mount the four angle brackets in these holes as shown in Figure 10. Be sure all six holes of each cover have clean metal on the *inside* surface. **Do not remove paint on the outside surface!** Be sure to use pan head screws on the bottom cover brackets and flat head screws on the top cover brackets. The holes in the top cover are counter sunk for the flat head screws. Check to ensure the brackets are oriented as shown. If you install the bracket backwards the case parts will not fit correctly.

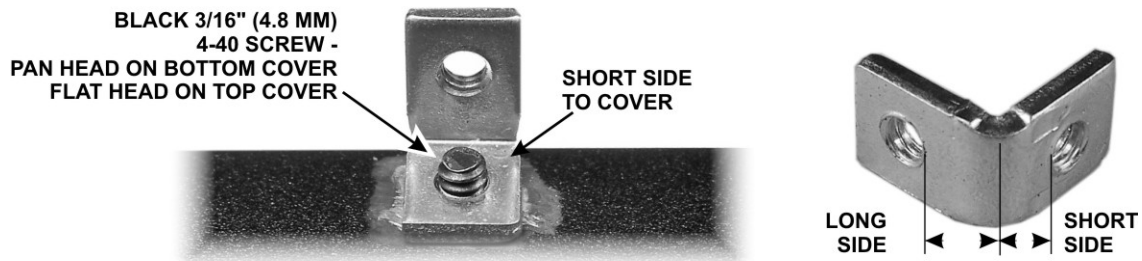

Figure 10. Installing Angle Brackets on the Covers.

Set the top and bottom covers aside in a safe place.

Locate the back cover. Check the area on the inside of the cover around each of the holes to ensure bare metal will contact the fasteners and connectors.

Locate the hole cover. It is a transparent strip on a paper backing with adhesive that fits over the Sensor, Keyboard, Ext Display and Aux data holes on the back cover. Do not break the strip on the perforations. They are provided to allow you to easily remove individual sections as needed later. Remove the backing paper and place the strip on the inside surface of the back cover, aligned so the two round holes are over the corresponding holes above and below the EXT DISP connector opening in the cover and press it firmly in place (see Figure 11). There is no adhesive over the areas that cover the openings so dust and dirt will not adhere to it.

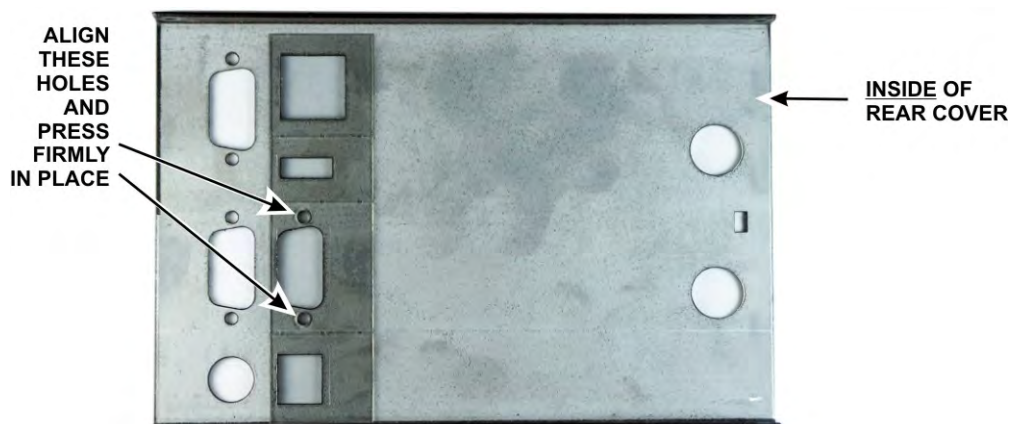

Figure 11. Installing the Hole Cover.

Remove the protective backing from the Serial Number label and carefully position it on the outside of the rear cover as shown in Figure 12.

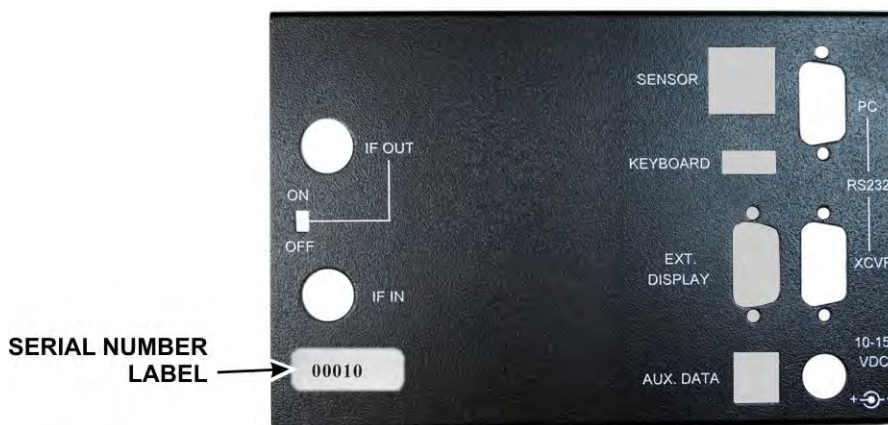

Figure 12. Attaching the Serial Number Label.

Mount a 2D fastener in the screw holes in the back cover top and bottom flanges just as you did for the front cover (see Figure 7 on page 39), using flat head screws in the counter-sunk holes on the top flange and pan head screws on the bottom flange. Be sure each fastener is oriented correctly with the widest shoulder toward the outside edge of the panel as shown in the figure.

☐ Remove the I/O printed circuit assembly from its anti-static packaging and check to see if either of the two multi-pin connectors have jack screw nuts installed (see Figure 13). These are the nuts the jack screws on the connector shells screw into to secure them. If either connector has jack screw nuts installed, remove them.

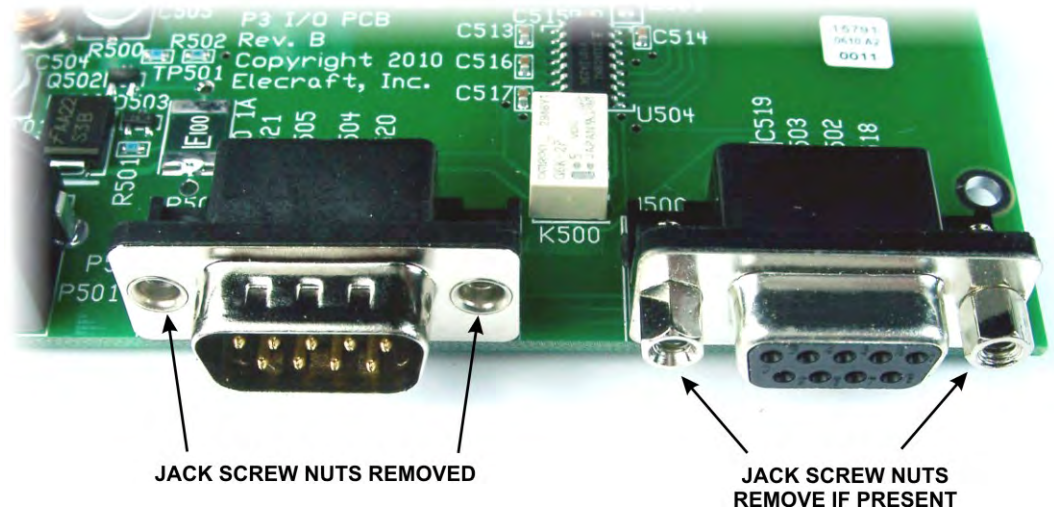

Figure 13. Preparing the I/O Board for Installation.

☐ Mount the I/O board on the rear panel with the connectors in the RS232 PC and XCVR holes as shown in Figure 14. It is held in place by the jack screw nuts as shown.

⚠ CAUTION: Do not over-tighten the jack screw nuts. It is possible to twist the hex nut section off of the threaded section with too much torque, especially if you are using a wrench to tighten them.

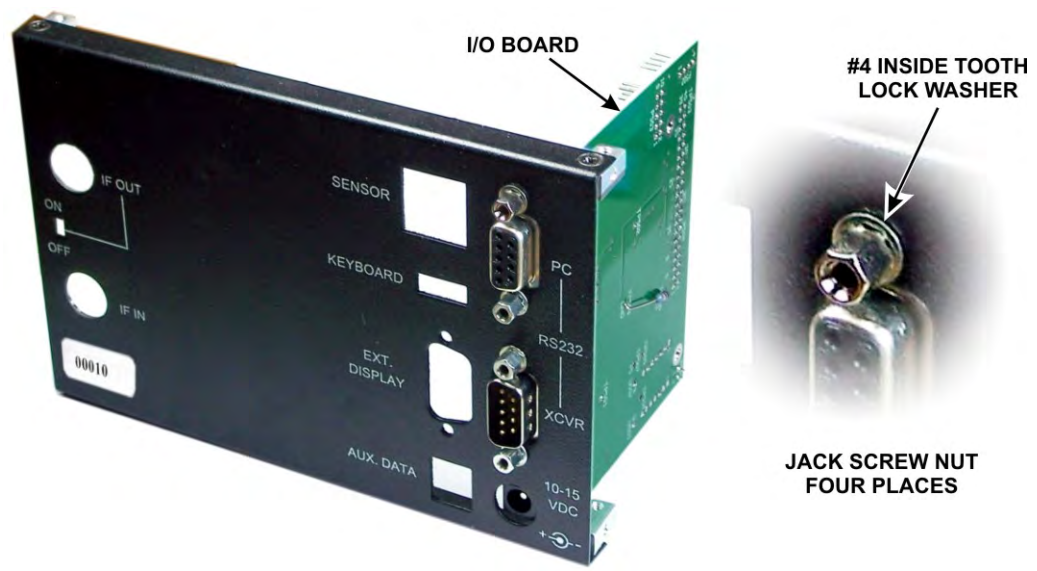

Figure 14. I/O Board Installed.

Locate the RF Board, the four 7/16" (14.3 mm) inside tooth lock washers and the two 7/16" (14.3 mm) nuts.

Mount the board on the rear panel as shown in Figure 15. Be sure two lock washers are between the BNC connectors and the inside surface of the rear panel and two lock washers are between the nuts and the rear panel as shown. **Tighten the nuts gently until they slightly compress the lock washers. That will hold the assembly securely in place. Over-tightening may place unnecessary strain on the RF board.**

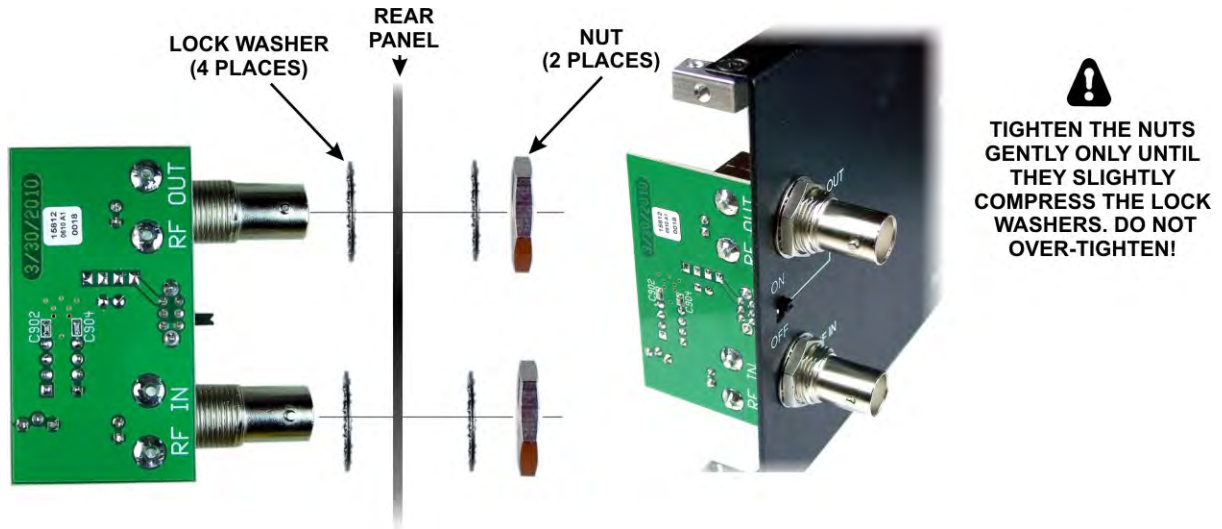

Figure 15. RF Board Installation.

⚠ NOTES:

1. The RF board connectors may be labeled RF OUT and RF IN while the rear panel is labeled IF OUT and IF IN. That is normal.
2. The remaining connector openings in the rear panel are for future use.

Mount the rear panel assembly to the end of the bottom cover that has the two round feet using a 3/16" (4.8 mm) pan head screw into each 2D fastener.

⚠ CAUTION: Severe damage to your P3 may occur if the 40-conductor ribbon cable is not oriented correctly and properly mated to the connectors as described in the following steps.

Retrieve the front panel assembly and locate the 40-conductor ribbon cable. Note that one edge of the ribbon cable is colored, usually brown or red.

- Plug the ribbon cable into P200 on the display board with the colored edge of the cable at Pin 1 (the bottom of the connector when the board is oriented normally). Be sure the connectors are properly aligned so all pins engage and they are fully mated as shown in Figure 16). One pin has been removed from the connector on the pc board and the corresponding hole in the cable connector is plugged to help ensure they are properly aligned end-to-end but check carefully to ensure the connector is mated to both rows of pins.

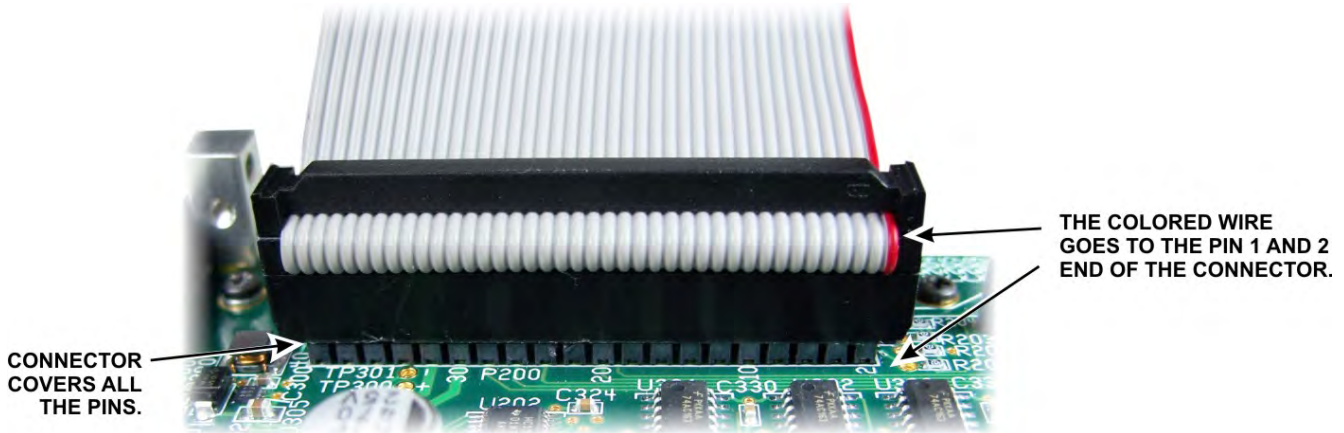

Figure 16. Mating the 40-pin Connectors.

- Mount the front panel assembly on the bottom cover end opposite the rear panel using a 3/16" (4.8 mm) pan head screw into each 2D fastener.
- Plug the free end of the ribbon cable into P504 on the I/O board. Be sure the red edge is at the Pin 1 end of the connector (the end nearest the bottom). To avoid stressing the board, support it with your fingers while mating the connector by placing your fingers on the side of the board opposite the connector and squeezing the connector in place with your thumbs. Be sure the connectors are properly aligned so that all pins engage the cable connector just as you did on the display board (see Figure 16).
- Locate the TMP coaxial cable. Plug one end into J902 on the RF board and the other end into RF IN, J100 on the front panel board. The connectors simply press into the sockets and are held in place by friction. If a connector refuses to engage, check for excess loose center conductor wires (see Figure 17).



Figure 17. TMP Connectors.

- Check the position of the jumper block on P502 on the I/O board (in the top corner just above the ribbon connector) and place it according to how you want the **POWER** switch to operate (see *Configuration* on page 24).

Complete the assembly of the enclosure as follows to make adjusting the fasteners for the best fit easy:

⚠ IMPORTANT: Do not over-tighten the case screws. You can strip the threads or damage and scratch the screw heads.

1. Mount the top cover. Orient it with the notch to the rear. (The notch is to make the cover easy to remove with a fingernail or small tool if needed.) Secure the cover with four 3/16" (4.8 mm) flat head screws.
2. Mount the two side panels after checking to ensure there is bare metal around the screw holes on the inside for good electrical contact. Although the panels are identical, they only fit one way so the holes align with the fasteners. If a screw binds or does not line up properly, loosen the other screws holding the 2D fastener or the screw into the L- bracket so it can move slightly for better alignment. If a side panel seems pushed away from the top and bottom covers at the center, check the L-bracket carefully. The usual cause is an L-bracket installed incorrectly (see Figure 10).
3. Inspect the enclosure from all sides, loosening and retightening screws while adjusting the panels for the best fit.
4. Ensure all the case screws are tight. Good electrical contact between the enclosure panels and the circuit boards is essential for proper operation.

That completes the assembly of your P3 Panadapter kit.

Servicing the P3

⚠ CAUTION: The PC Boards inside the P3 are ESD-sensitive. Wear an ESD-safe wrist strap or touch a metallic ground regularly at any time while working inside the P3. See *Preventing Electrostatic Discharge Damage* on page 34 for more information.

Accessing the PC Boards

There is a small slot at the back of the top cover that allows you to lift it easily with a fingernail or small tool once the screws are removed. The P3 with the top cover removed is shown in Figure 1 on page 35.

The P3 uses Elecraft's unique 2D fasteners which allow you to remove the top, bottom, front, rear, either side or any combination of panels independently. The fasteners are shown in Figure 7 on page 39.

⚠ If a case screw is too tight to remove, it is probably because tightening the other screws in that fastener caused it to bind against the side of the screw hole. Loosen the other screws in that fastener to free it.

The top, bottom and sides are supported at the center by L-brackets (Figure 10 on page 40).

The TMP connectors on the coaxial cable joining the front panel and RF boards are friction fit. To remove, pull on the metal ears on the connector. A slight twisting motion will help free a tight connector. ***Pull on the metal ears. Do not pull on the coaxial cable*** (see Figure 17 on page 44).

The rear-panel pc boards are held in place by their connector hardware (see page 43).

Remove the knob to remove the front panel board. The knob is held by friction (see Figure 6 on page 38).

The front panel board is secured to the front panel by the four screws at the corner of the LCD display. The LCD panel is held in place by friction against the rubber key matrix that surrounds it. Handle the assembly carefully to avoid dislodging the LCD. If you need to remove the LCD, see *Replacing the LCD Display* on page 47.

If you need to replace the front panel display board, transfer the four standoffs shown in Figure 4 on page 37 to the new board. ***Be sure to replace the lock washers between the standoff and the pc board as shown in the figure.*** Do not over-tighten the screws holding the plastic bezel and pc board on the front panel.

When reassembling, be sure the 40-conductor ribbon cable is not twisted. The colored edge should go to the pins 1 and 2 end of the connectors on the circuit boards. Pins 1 and 2 are on the end nearest the bottom of the P3 when they are installed. Be sure you have the connectors aligned so they engage all the pins. Note that one pin is missing and the corresponding hole is plugged to help you align the connectors, but it is still possible to leave one row of pins exposed.

⚠ CAUTION: Severe damage to your P3 may occur if the 40-conductor ribbon cable is not oriented correctly and properly mated to the connectors as described above.

Cleaning the LCD Bezel

When the power is off and the LCD is dark, fingerprints and dust become clearly visible on the bezel covering the LCD screen. Avoid rubbing the bezel. It is easily scratched. Use a very soft cloth and gentle pressure. If the bezel requires more extensive cleaning or cleaning on the inside surface, remove the front panel assembly, lay it face up and then remove the four screws holding the bezel. Note that this will also release the front panel circuit board with the LCD. Mild liquid dish soap is a good cleaner and has the effect of dissipating dust-attracting static charges. Blot the bezel dry rather than wiping it.

If the LCD itself is dirty, use a soft cloth to wipe it clean. If necessary, dampen the cloth slightly with a mild cleaner (lens cleaner for eye glasses is good). The front surface of the LCD is a plastic polarizing filter that is essential for its operation. This filter is easily scratched.

Replacing the LCD Display

Remove the front panel board with the LCD display from the P3 front panel. **Be careful not to damage the tiny transformers on the component side of the board (see Figure 2).** Place the board on your work table with the top of the board nearest you. Arrange a book or other object about level with the key matrix against the bottom of the front panel board to support the LCD when you free it from the key matrix (see Figure 18).



Figure 18. Removing LCD Panel from Rubber Key Matrix.

Gently pry up the top edge of the LCD panel to free it from the switch matrix and fold it over onto the support as shown. Don't strain the two delicate ribbon cables or their connectors.

Use a fingernail to open the connectors and free the cables (see Figure 19). Be especially careful with the smaller connector. Note it opens from the end farthest from the cable. The white latch opens only slightly.

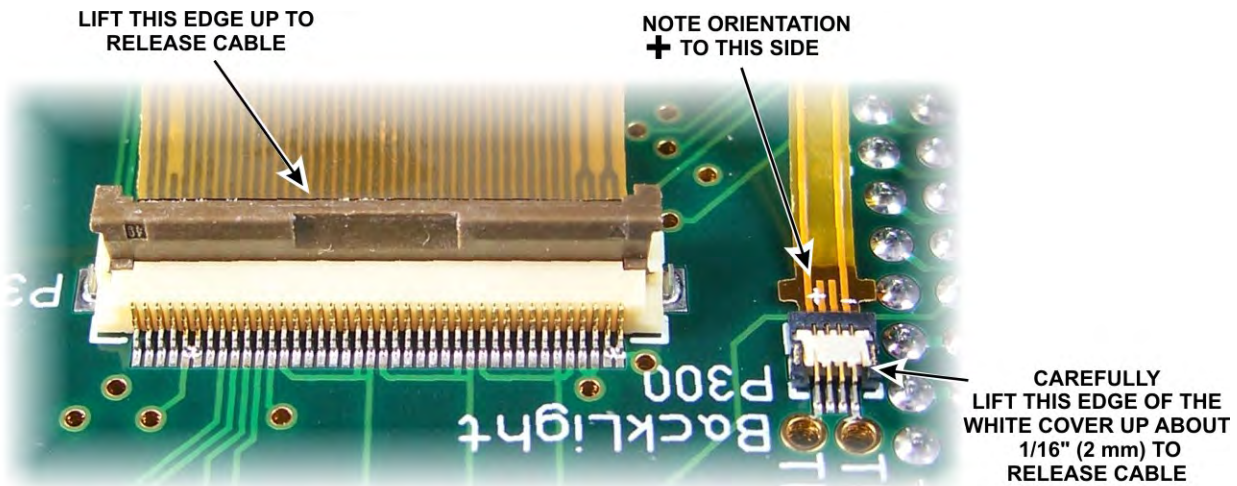

Figure 19. LCD Cable Connectors Opened.

When replacing the cables, be sure the smaller backlight cable is oriented with the + as shown.

Gently replace the LCD in the switch matrix. Be sure it is fully seated so the edge of the LCD panel is flush with the surrounding rubber matrix.