

# K2's Mic Configuration Header Extender and Rear Panel DATA Connector

By Paulí Nuñez, EA3BLQ

I am a fan of Digital Modes (mainly PSK31, SSTV and RTTY), and ever since I finished the construction of my K2, I wondered how could I implement a rear data connector that would facilitate the rig's interface to the computer, without interfering with the mic front connector and without muting the sound of the signals, as it happens when it is taken from the K2's front panel connector or the rear external speaker jack, to feed the interface. I could get the received signal directly from the AF and GND lugs in the external loudspeaker jack, as I would like to recall that somebody pointed out some time ago in the list, but the level of all those outputs depend on the setting of the AF GAIN pot, and while working any of the above modes I like to listen to the incoming sound but, whether I have the headphones on or not, I like the sound to be low level, like a "soft background music". As a result I needed a steady and independent signal to feed the sound card, and that meant that I had to get it from some place in the rig before the receiver's amp stage, i.e: J5, the auxiliary audio output in the RF board.

At the same time I needed to convey the AF, PTT and GND signals from the Mic Configuration Header to the DATA connector. As a first thought, this could only be achieved by soldering or wire wrapping appropriate leads on the relative pins in the configuration header, precisely what I didn't want to do. I was considering the use of a 16 pin IDC connector and flat ribbon cable, but then, how could I configure the mic? On September 18, 2000 Tom, NØSS, brought out and posted Dave's, W1EUY, idea of using an IDC header connector as a programmable plug to permit easy configuration of the K2's mic. It was then that I thought, "Of course this is the way!". I needed an extension of the mic configuration header to take it, the header, out of its hidden and rather inaccessible place at the Front Panel Board. I had to do it in a way that I could always have available a handy replica of the header, at the same time that I got the needed signals for the DATA connector.

To complete my train of thought, I tried receiving PSK31 by using the signal present in J5 (aux. audio output). It worked, but I found the level I got to be a bit too low, so it needed to be amplified. After some research and bearing in mind that there are 5V DC present in one of the header's pins, I decided that the Low Voltage Audio Amplifier IC, LM386, which can operate with a Power Supply Range of +4 - +18 VDC and has very low current drain, was a very good candidate.

And that is how the following circuit came to life.

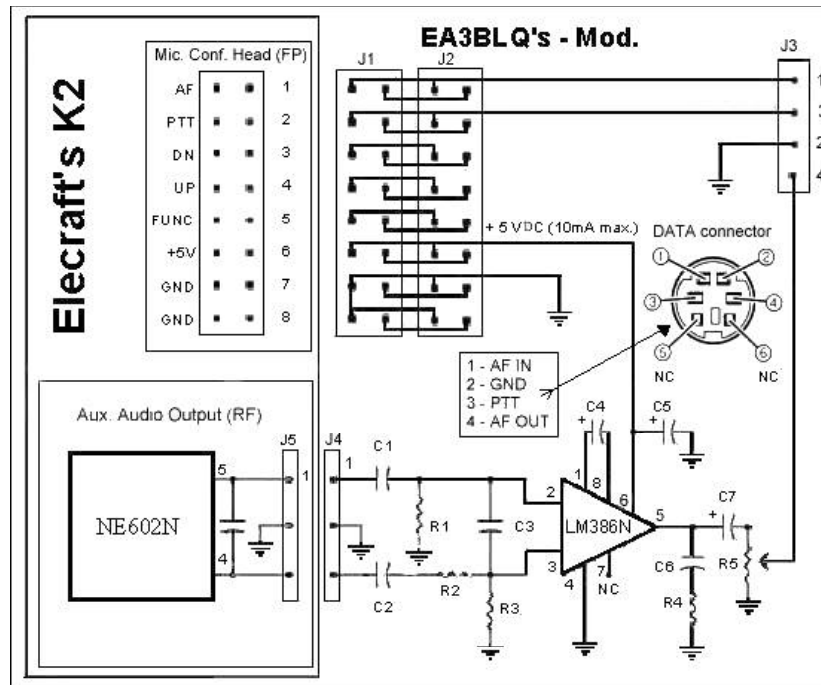


Fig 1.- Schematic

As you may observe, J1 is the recipient, through a ribbon cable, of all the inputs and outputs of the mic configuration header on the FP board, and J2 becomes a replica of that header in such a way that the mic configuration can be set and changed as needed, without having to unplug the Control Board to reach the header.

J3 is connected to the rear DATA connector and its pin numbering corresponds to that of the DATA connector as follows: Pin 1 is the input of the AF signal to be transmitted, coming from the computer; pin 2 is GND; pin 3 receives the PTT signal to key the K2 and pin 4 is the output of the received signal after it has been amplified. This pin layout is the same used by Kenwood in their 144 MHz and 430 MHz all mode transceivers TM-255 and TM-455.

J4 is the input of the balanced received signal coming from J5 on the RF board (mind the numbering of J2 and J4 pins) that it is fed into the Low Voltage Audio Power Amplifier, LM386, powered by the 5 VDC available in the header. The IC's current drain is very low (4mA.). The gain of this IC is internally set to 20 but externally can be increased to any value from 20 to 200 by means of a resistor and capacitor in series between pins 1 and 8. I decided to use just one 10  $\mu$ F 10 V electrolytic capacitor (C4) between those pins to get maximum gain. The level of the signal fed to the sound card so as not to overdrive it, is set through R5, one 470  $\Omega$  trimmer pot.

I have used four metal stand-offs and eight screws to fasten the extender PB (Figure 8) to the bottom side of the top cover, on the right front side, near the speaker. In this way the rear half side of the top cover is free to house other options.

The DATA connector is installed in the rear panel of the top cover, close to the external speaker jack. (see Fig. 9)

The ribbon cable to connect the configuration header to J1 may come out from the front panel board through a little gap existing between the control board and the left side panel or between the top side of the control PB and the top cover. (see Fig. 8)

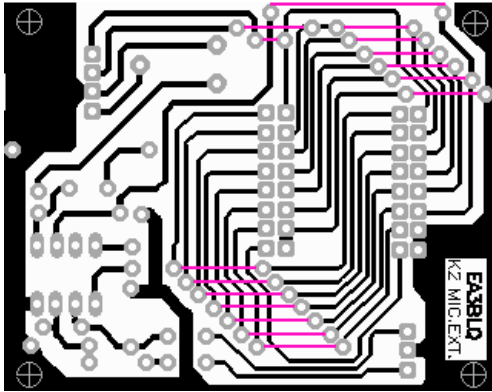
The cables connecting J5, in the RF board, to J4 in the extender PB, and J3 in the extender PB to the DATA connector, at the rear panel, are shielded.

Those K2 owners who may wish to use the K2's mic connector, rather than the rear connector I am proposing, to interface their rig with the computer to work digital modes, can do so and still take advantage of all the facilities of this project, by connecting pin 4 of J3 to any available pin (say pin 3 to pin 7) in the mic header replica, J2, and thus have the needed received AF signal available at one of those pins. Those K2ers perhaps may wish to have two IDC header connectors as programmable plugs to permit an easy configuration of the K2's mic, one for the microphone they are normally using for SSB operation and the other for Digital Modes (PSK31, SSTV, RTTY ...).

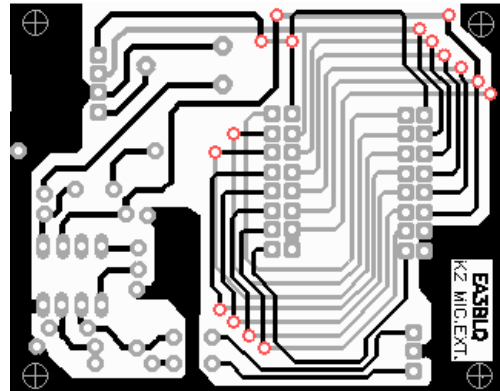
*Warning to those K2ers using the rear connector.*- Please bear in mind that, if you have a microphone connected to the K2 while working digital modes, when the software will key the rig through the PTT line to transmit data, the ambient noise of your shack may also be transmitted into the air through the mic. Thus I strongly recommend to unplug the mic from the K2 when working those modes.

## PRINTED CIRCUIT BOARDS

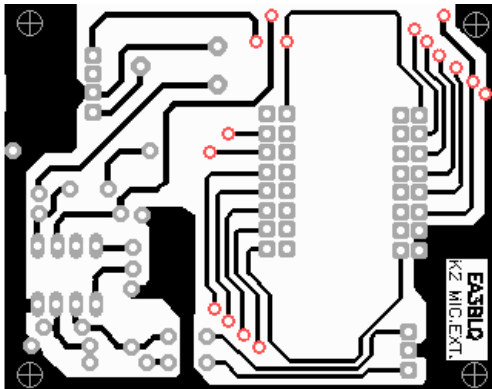
The making of J2 an exact replica of J1 is not easy in a relatively small PCB (2" x 2 9/16" [51 mm x 65mm]). The first design was a single sided PCB (Fig. 2) but it required the user to install up to 16 bypass jumpers needed. It served for a first test with satisfactory results but it was rather cumbersome to construct. So a two sided PCB was also designed and Fig. 3 shows both sides of the Board, the images are merged so as to enable the sight tracing of the tracks (tracks in the bottom side are coloured black, and those in the top side are grey. The red holes are the via that provides conductivity between both sides of the board and are plated through)



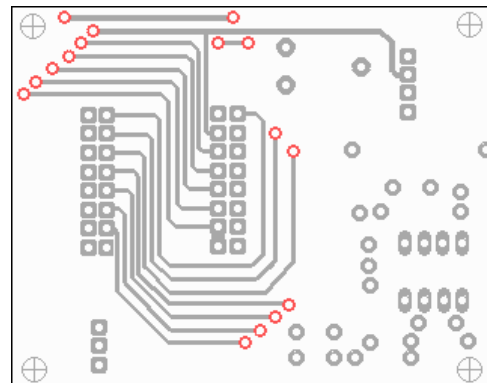
**Fig 2 .-** Single sided PCB (foil side). Pink lines correspond to the 16 bypass jumpers needed.



**Fig 3.-** Double sided PCB. Soldering pads are also plated-through.

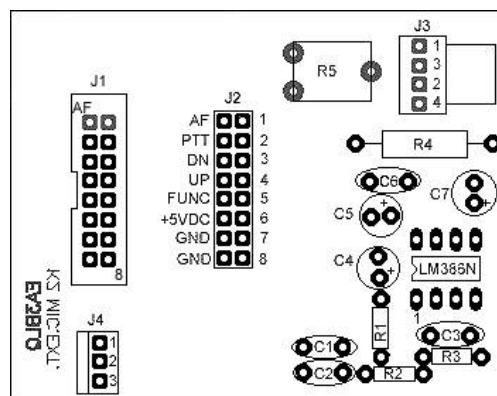


**Fig 4.-** Double sided PCB (foil side)



**Fig 5.-** Double sided PCB (component side)

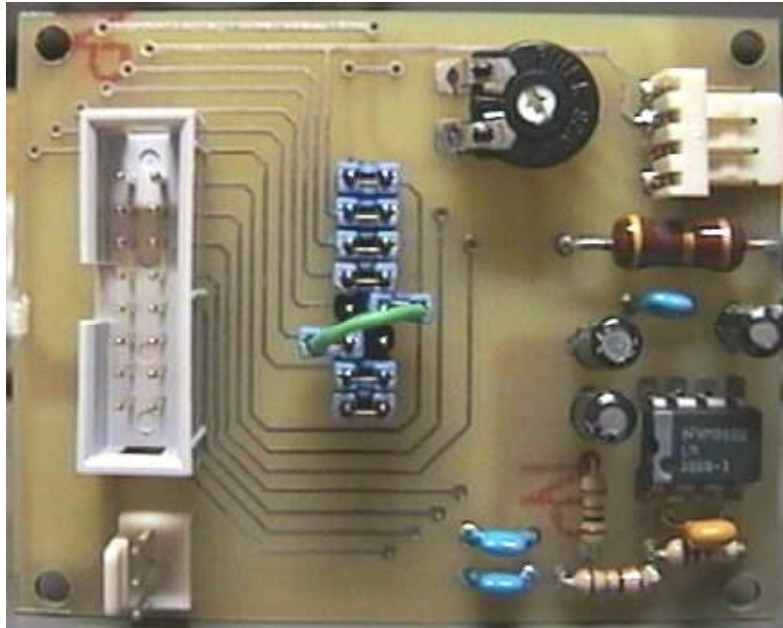
The component layout shown in Fig. 6 is valid for both single and double sided boards but for the bypass jumpers needed in the single sided.



**Fig 6.-** Component layout as viewed from the component side of the double sided board.

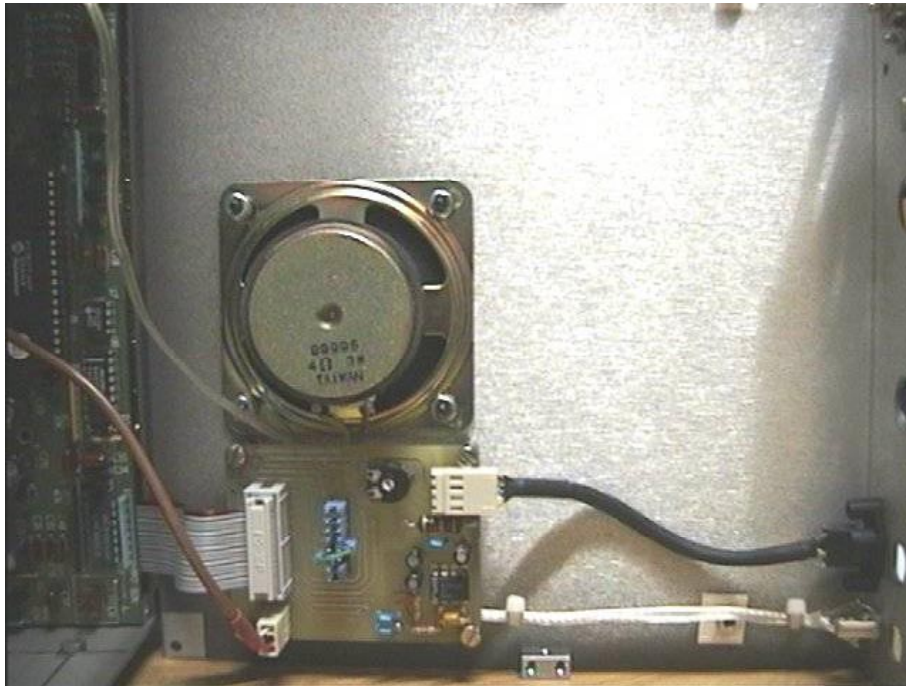
## SNAPSHOTS

Fig. 7 is a close-up of the complete PCB finished and ready to be installed on the bottom side of the top cover, close to the speaker. Note the replica of the extended header already configured for the MC-85 mic from Kenwood (I have used computer jumpers for configuring. Of course, an IDC header connector can also be used as a programmable plug).



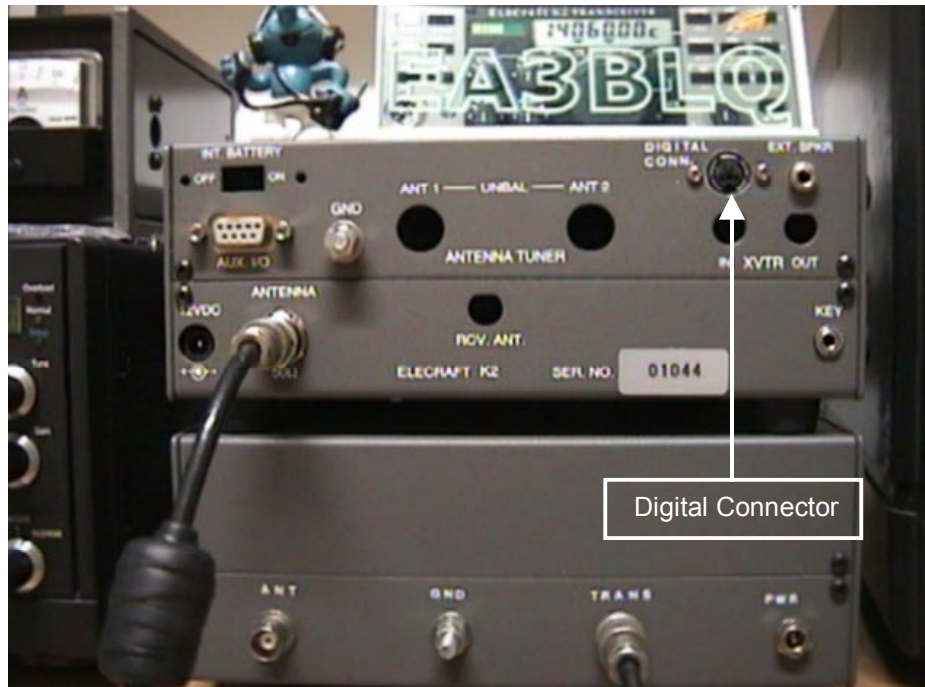
**Fig 7.-** Close-up of the constructed PCB

Fig. 8 shows the assembled K2 and the top cover, with the mod PCB installed, ready to be placed onto the chassis. Note the four lead shielded cable that connects J3 in the extender PCB to the DATA connector in the rear panel of the top cover, running parallel to the speaker cable.



**Fig 8.-** PCB already installed. Observe the ribbon cable emerging between the Control and Front Panel boards

Fig. 9 is a snapshot of the rear panel showing the installed DATA connector at the left side of the external speaker connector.



**Fig 9.-** Rear K2 Panel

I have been using this modification for more than three months now and have not had or noticed any trouble whatsoever.

I expect this project will be of the liking of many a digital modes' fan K2 owner.

Any ideas to improve this PCB's layout and/or the circuit itself will be most welcome.

© Paulí Núñez, EA3BLQ, 15-01-01

[ea3blq@eresmas.net](mailto:ea3blq@eresmas.net)

[ea3blq@arrl.net](mailto:ea3blq@arrl.net)

# Parts list

## Resistors

R4	4.7 $\Omega$ 1w
R2	1.5 K 1/4 w
R1, R3	10 K 1/4 w
R5	470 $\Omega$ Trimmer pot (mod PT-10)

## Condensers

C3	0.047 $\mu$ F ceramic (473)
C1,C2,C6	0.1 $\mu$ F ceramic (104)
C4, C5, C7	10 $\mu$ F 10 V electrolytic

## Integrated Circuit

IC	LM386N
----	--------

## Miscellaneous

- 1 6 pin mini-din DATA connector (Kenwood style)
- 2 16 pin IDC Header female connectors
- 1 16 pin IDC male connector (J1)
- 1 16 pin dual-row male connectors (J2)
- 1 4 pin right angle male connector w/locking tab (J3)
- 1 4 pin female housing w/locking ramp and 4 crimp pins
- 1 3 pin male connector w/locking tab (J4)
- 1 3 pin female housing w/locking ramp and 3 crimp pins
- 1 3 pin male for J5 at the RF board

16 lead flat ribbon cable, 5" (127 mm) of length, to connect the mic configuration header, at the front panel board, with J1 in the Extender PB

4 lead shielded cable, 4" (102 mm) of length, to connect J3 at the Extender PB to the DATA connector in the K2's top cover's rear panel.

3 lead shielded cable, 6" (152 mm) of length, to connect J5 at the RF board to J4 at the Extender PB