

SP2 Companion External Speaker for the Elecraft K2

By Dave White, VE6DRW

2004.09.21

The SP2 is an external companion speaker for the Elecraft K2. It is housed in the Elecraft EC-2 enclosure that is designed to match the style and size of the K2. The primary design goal of the SP2 was to improve on the sound quality and loudness of the stock K2.

The original intent of the SP2 project was to develop a prototype in preparation for production and sale of an Elecraft accessory kit. A combination of factors -- most of them business related -- has prevented the SP2 from reaching production. Thus, these design notes are being made available to the Elecraft community for those interested builders who may want to duplicate the SP2 on their own.

In addition to myself as project lead, the following dedicated Elecrafters supplied creative and thoughtful input into the design and testing of the SP2:

Bob Abell VE3XM	Don Brown KD5NDB
Wayne Burdick N6KR	Tom Hammond N0SS
Steve Jackson KZ1X/4	Mychael Morohovich AA3WF
Robert Parker VE3RPF	Eric Swartz WA6HHQ
Bob Tellefsen N6WG	Don Wilhelm W3FPR

The SP2 uses a single 4" front-firing driver in a "sealed" enclosure design. The speaker is mounted on a baffle plate tilted at an angle to fit the height of the EC-2. Cabinet resonances are damped by applying a special sound absorbing material to the interior walls of the cabinet.

To compensate for the lower efficiency of the driver, a small amplifier powers the speaker. The amplifier contains a low pass filter to reduce high frequency noise and a mute circuit that allows remote muting of the speaker. In addition, front mounted switches control the SP2 power and speaker activation. A front-mounted headphone jack is included that is independent of the speaker ON-OFF switch. Thus, it is possible to mute the speaker independent of the headphones. A LED indicates power to the unit. Rear connections are provided for power, mute and input (from the K2 external speaker jack). A bottom-mounted trim level control is provided for matching input levels. The SP2 is fed from the external speaker output of the K2.

The SP2 achieves all of its design goals as demonstrated by the accompanying graphs. Low frequency response is significantly enhanced and the overall response curve is much smoother than the stock K2. The low pass filter removes a significant amount of high frequency noise above 3.2Khz. The addition of the amplifier allows almost any volume level to be achieved; the output power of the amplifier is about 4 watts (RMS) and the rated drive level of the speaker is in excess of 5 watts. All of the measured results were confirmed by subjective listening tests of the project group.

Construction

These are NOT step-by-step instructions (ala an Elecraft kit). Rather, they are designed as guidelines for the builder with moderate to advanced skills; especially in the area of metalworking. Much of the success and quality of the finished product is dependent on the precise fit of the front grill and speaker baffle plate, thus the construction focuses on these details. The reader is advised to thoroughly review the construction details until they are confident they can duplicate the effort. A parts list is included on page 9. The following diagrams give the modifications and measurements to a stock EC-2 enclosure. **The diagrams are NOT to scale; use the dimensions listed.**

Front Panel

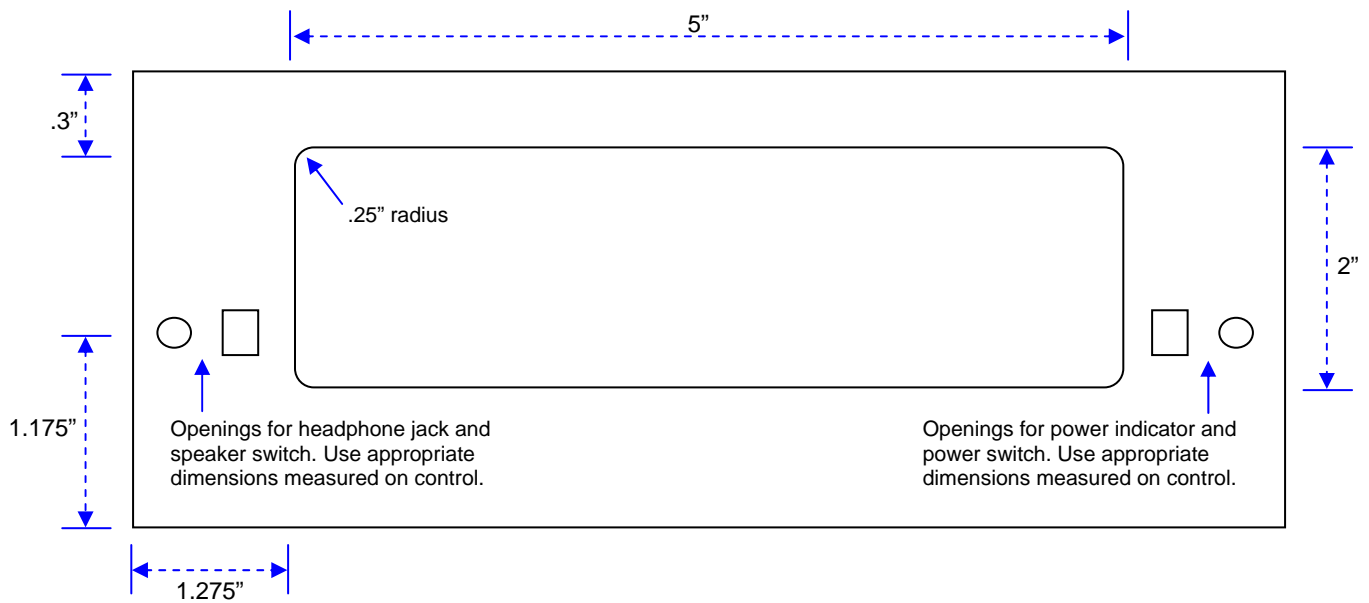

Front Grill

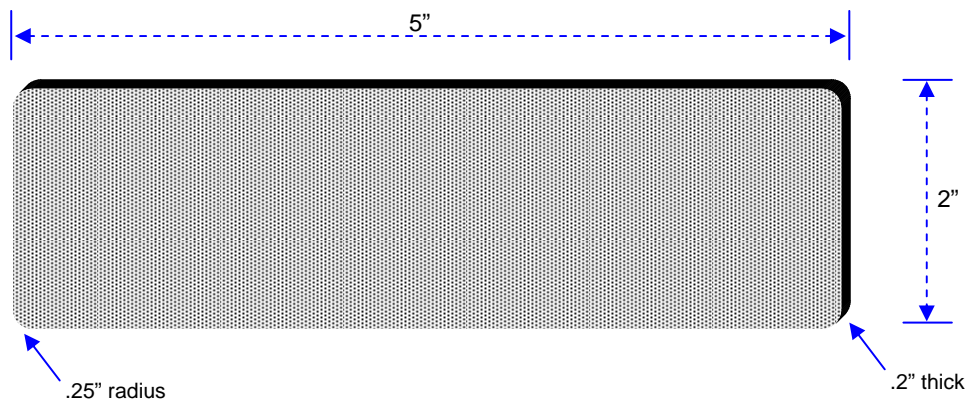

The front grill is constructed of "thin" aluminum mesh material (similar to that found in car aftermarket speaker grills) and to dimensions that will allow a moderate friction fit into the front panel opening. Pressed in from the back, the grill protrudes about .1" from the front panel. The reader may want to devise some other method for holding the grill in place besides a "friction fit".

Speaker Baffle

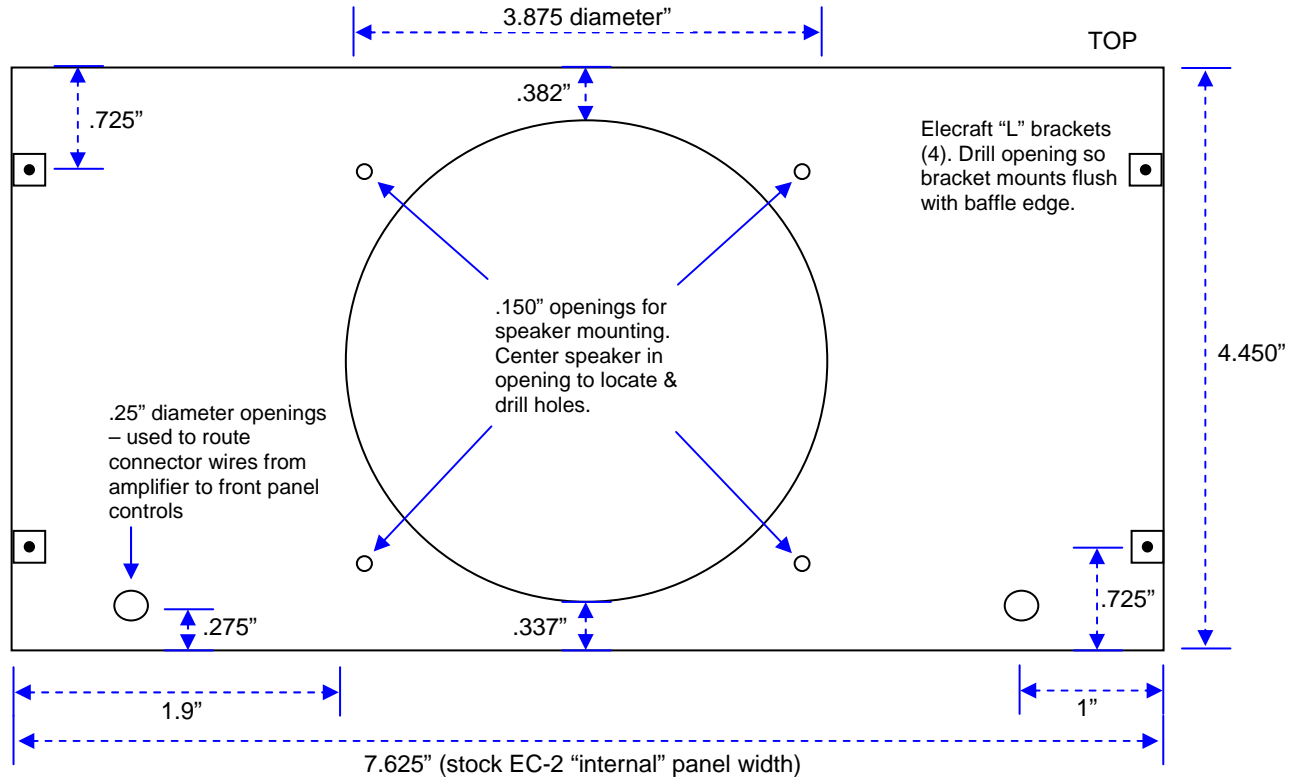

The balance of the EC-2 panels (sides, back and bottom) will require additional openings. Their locations are best determined at construction time as "custom fit". This is especially true of the mounting holes in the side panels for the speaker baffle plate. Carefully examine the accompanying photographs for assistance with the rest of the construction details.

After preparing the panels as shown, cut a piece of the VB5 foam material (see parts list) and apply it to the FRONT of the speaker baffle plate. Trim the edges of the foam flush with the edges of the plate, as well as the opening for the speaker and all other openings. Trim enough of the foam to ensure that the "L" brackets and speaker spacers will sit flush on the plate.

Cut a piece of the VB5 foam material (about .6" x 7.625") and apply it to the inside of the front panel between the speaker grill opening and the lower lip. It will be used to seal the speaker baffle plate to the front panel.

Trial-assemble the speaker to the baffle plate. The speaker mounts IN FRONT of the baffle (as shown). 6-32 washers may be required between the spacer and the speaker basket to space the speaker so that the basket compresses the VB5 foam material without bending the speaker mounting tabs. Mount the "L" brackets on the back side of the speaker baffle plate.

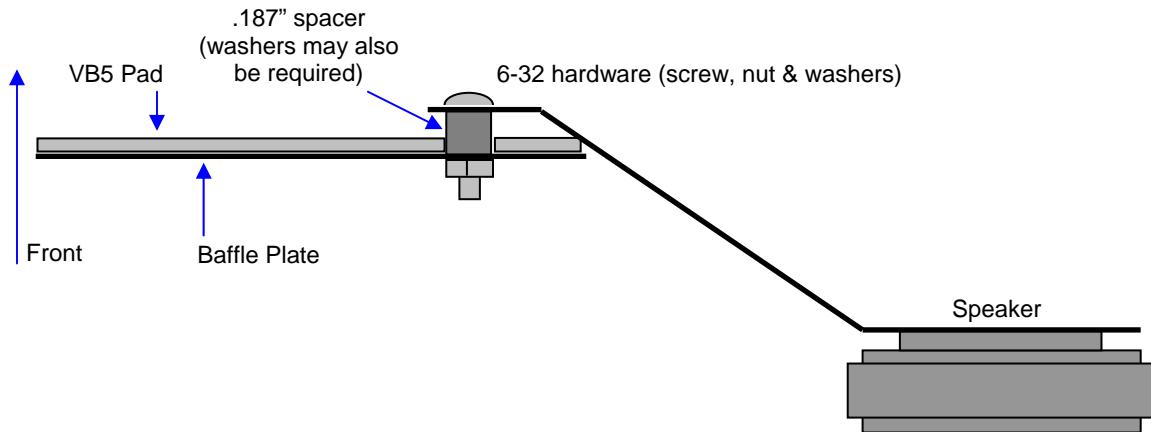

Assemble the EC-2 enclosure using the supplied hardware complete with the panel. The baffle plate and speaker will be inserted shortly. Insure that the seams of the enclosure are tight and that the enclosure is square. Tighten the hardware.

Carefully remove one side panel and the bottom plate. With the enclosure lying on the side panel not removed, carefully insert the speaker baffle plate into the enclosure. Using thumb pressure on the speaker basket, press the baffle plate towards the top and the front of the enclosure so that the VB5 foam on the front panel is slightly compressed and the VB2 pad on the top of the baffle plate contacts the top of the enclosure. Test-assemble the bottom to the enclosure to insure there is clearance between the speaker magnet and the bottom panel. This may require rocking the panel back and forth slightly to achieve the correct fit (see photos). Mark the locations of the “L” bracket openings in the side panel. Remove the panel, drill the holes (.125”), and remount the panel. Attach the baffle plate using the 4-40 screws to the “L” brackets. Mount the other side panel, and with the enclosure upside down, mark the location of the remaining “L” brackets for the other side panel. Be sure to align the baffle plate so it is square in the enclosure. Remove, drill, and re-attach the side panel. Mark the enclosure top with a line where baffle plate and top intersect. The enclosure can be disassembled at this time.

Trial-assemble the amplifier circuit board to the back panel. Mark and drill any required openings (as there is no supplied circuit board, your mounting requirements will vary from the prototype).

Apply VB2 damping pad material to the insides of the back, bottom, top (leaving ¼” wide gap on either side of the previously marked line) and side panels (up to the “L” bracket locations). Trim the pad material around the 2D fastener blocks and leave enough room at the edges for enclosure assembly. Audio performance will not be affected if the pads are slightly smaller than the panels. See photos.

Final assembly can proceed. Specifics will depend on your amplifier construction, but in general, assemble the amplifier to the rear panel, install the front panel controls and grill, and assemble the enclosure -- leaving the bottom and one side off so that the speaker baffle can be installed and the front panel controls wired.

Assembly Photos

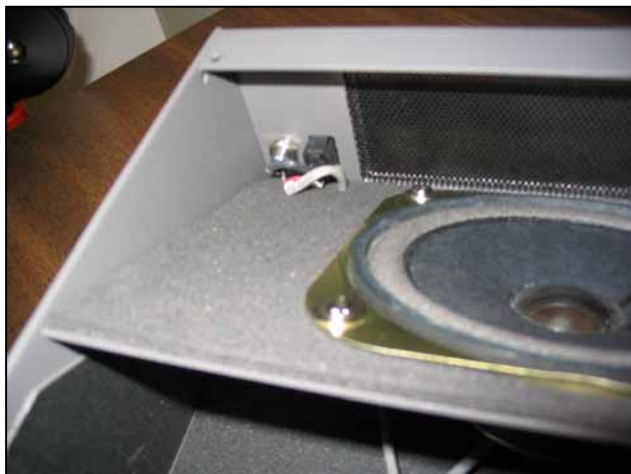

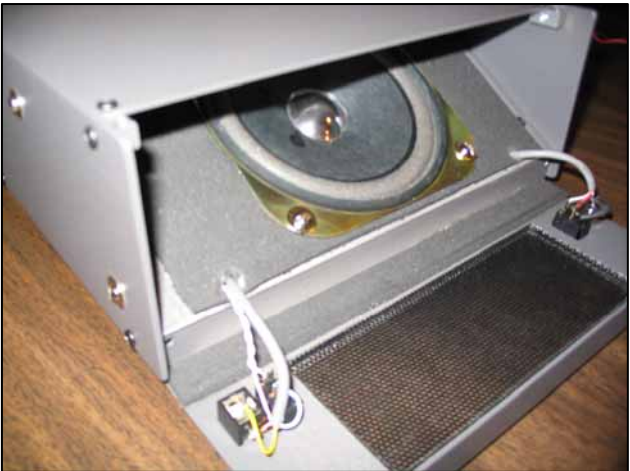

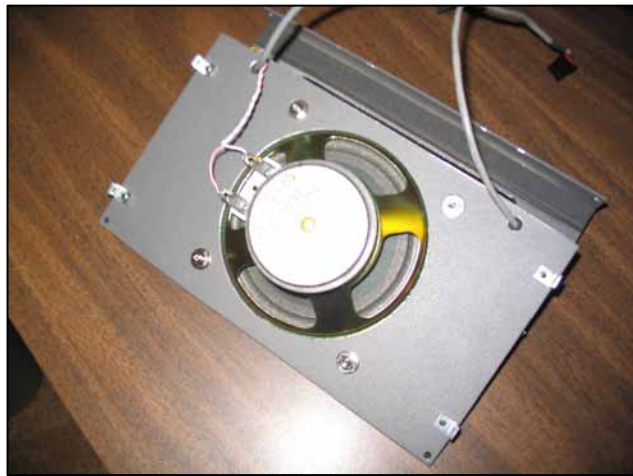



Parts List (Enclosure ONLY – See schematic for amplifier parts)

QTY	Part #	Description	Supplier
1	EC-2	Enclosure Kit	Elecraft
4	N/A	"L" Brackets	Elecraft
1	GF-1004ND	8 ohm 4" Speaker (6 Watt)	DigiKey
2	VB2	Audio Damping Pads (10" X 10")	Cascade Audio Engineering
1	VB5	Foam Damping material (8" X 8") (May substitute equivalent material – ie weather-stripping)	Cascade Audio Engineering (www.cascadeaudio.com)
4	N/A	6-32 speaker mounting hardware 3/4" (screw, nut & washers)	N/A
8	N/A	4-40 black pan-head screws (side panel to speaker baffle mounting screws)	Elecraft
4	N/A	.187" nylon spacers with .138" hole(speaker mounting spacers)	N/A
2	N/A	Rocker Switches (or equivalent) (speaker and power ON-OFF)	N/A
1	N/A	1/8" 3 circuit. phone jack (headphone jack)	N/A
1	N/A	12VDC LED power indicator	N/A
	MISC	Hookup wire	N/A
	MISC	Aluminum expanded or perforated metal (4" X 7") (Speaker grill)	Used car speaker grill
	MISC	16 gauge Aluminum plate (5" X 8") (Speaker baffle plate)	N/A

Amplifier

Refer to the schematic for details of the amplifier configuration. The unit consists of two LM380N ICs (14 pin case) configured for bridged delivery to the speaker (BTL). The amplifier is preceded by a low pass filter with a cut off frequency of 3.2Khz. The filter is preceded by a simple mute circuit. A common mode “set and forget” gain control allows the overall system gain to match the specific K2 audio output characteristics. DC power can be any value from 10 to 15VDC; a maximum of 4 watts (RMS) output power is available at 14.0VDC.

A bridged configuration means that both sides of the speaker float above ground. DO NOT ground either side of the speaker or damage to the amplifier could result. The headphone output is driven from one side of the amplifier through a decoupling capacitor and dropping resistor R9. The value of R9 can be adjusted (minimum 39 ohms) by the reader to yield a balanced level between the speaker and the headphones.

All components are readily available from regular sources (DigiKey, Mouser, Jameco, and so on ...). Altering component values, especially around the filter, could result in dramatically different results.

There are many other amplifier configurations that would also work. A single IC configuration with built-in mute was suggested by several testers. Preliminary research indicated that the National LM4950 or ST Microelectronics TDA 7266 might be suitable choices (keep in mind that the speaker is an 8 ohm driver). These, however, may be difficult to source in small quantities. No testing of these alternatives was performed before the project was terminated. (Update: Tom Hammond, NOSS, has tested the LM4950 with disappointing results).

Amplifier construction is not critical. The prototype was built on a soldered breadboard. Although RF feedback into the amplifier was reported in only one instance by the test group, the reader may want to add RF suppression components to the power and input leads. Keep in mind that the ICs will run hot, so adequate heat sinking is required. The prototype used the EC-2 back panel as a heat sink by inverting the amplifier board and resting the IC cases on the bottom of the case (using silicon thermal compound). This provided adequate cooling.

Performance Data

Several graphs of the speaker and amplifier performance are included. These are provided for reference only and the reader can interpret the results as they see fit. No claims are made that this is the optimal external speaker configuration, but given the design limits, the subjective listening tests confirm the chart results; the speaker offers a significant improvement over the stock K2 design for both SSB and CW reception while increasing the audio output available from the K2. With a wide variety of testers, a broad section of K2s were sampled from field test units to current production models. Both the KDSP2 and the KAF2 audio filters were used with the SP2 and the results were universally positive.

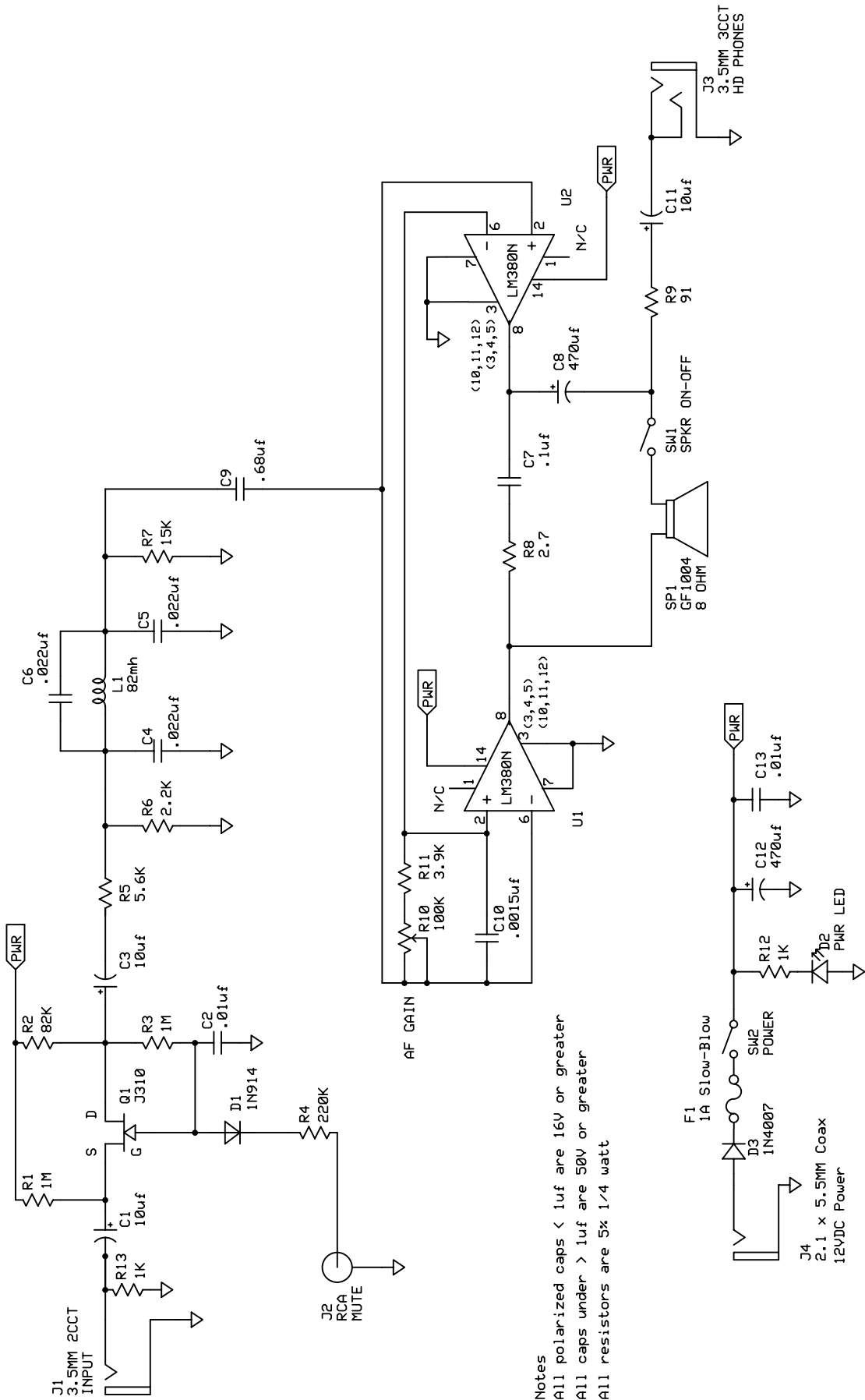

Notes
 All polarized caps < 1uf are 16V or greater
 All caps under > 1uf are 50V or greater
 All resistors are 5% 1/4 watt

Part 2: Test 1

Test 1 Variation	Single 4" GF1004 8 ohm in Sealed Damped EC-2 – Small Room Test Stand	
Test 1 Conditions	Input Source: Computer S/C	Pickup Type : GoldLine PRO
	Input Signal Type : Pink Noise	Pickup Distance (Meters) : 1.0
	Input Signal Range : 0 db – Amp gain adjusted for PWR output	Pickup Orientation (V) : See Below
	Input Power to Object (Watts) : 1/2Watt RMS @ 1Khz	Pickup Orientation (H) : See Below
	Software Settings: 100 -5000Hz – 1/24 th octave – 80Hz Response – 10 Avg. – (-70 to +10 db scale)	
Observations	Average SPL (db): See Below	Subjective Tone Quality: None
	Comments: small room conditions – well damped – typical "shack"	
Response Graph 1:		
<p>Description: Small Room Test Stand</p> <p>Pink SPL: 80db</p> <p>V Orientation: 0 degrees</p> <p>H Orientation: 0 degrees</p>	<p>Description: Small Room Test Stand</p> <p>Pink SPL: 81db</p> <p>V Orientation: +30 degrees</p> <p>H Orientation: 0 degrees</p>	
Response Graph 2:		

