

K3 Receiver Antenna Routing

The simplified block diagrams in this section show how antennas are routed to the main and subreceivers. The heavy line shows the default RF path. All antennas are protected from electrostatic discharge by surge arrestors. Receive-only antenna inputs include carrier-operated relays, indicated by asterisks (*).

ANT 1 and AUX RF

As shown in Figure 1, the basic K3 is supplied with one SO239 jack (ANT1). The signal from ANT 1 is routed through the antenna input module to the main receiver, as well as to the transmitter. The subreceiver can share the ANT 1 signal via a passive splitter and relay K1. When the subreceiver is off or is switched to its auxiliary RF input, K1 bypasses the splitter so it will have no effect on either receiver.

An extra RF I/O connector location is provided (AUX RF, BNC). The subreceiver's auxiliary input can optionally be routed to this connector. K1 then selects either the main RX path or AUX RF as the subreceiver's RF source. The subreceiver has its own full set of ham-band and optional general-coverage band-pass filters (KBPF3), but its image rejection will be best when sharing the main path, which includes the receive/transmit low-pass filters.

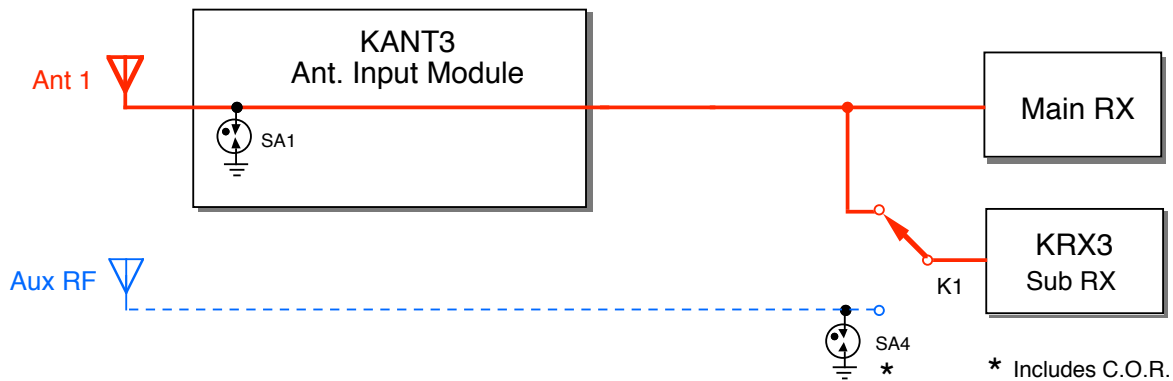

Figure 1. Basic Main/Sub Receiver Routing (no KAT3 or KXV3)

RX Antenna Input (KXV3)

If the KXV3 option is installed (Figure 2), a separate receiving antenna can be connected to the RX ANT IN jack. Relay K2 then selects either ANT1 or RX ANT for the main receiver. Low-pass filters will not be in the path when RX ANT is selected. This will rarely be an issue, since the main receiver has a full set of ham-band band-pass filters, and since many receive-only antennas are low-gain and/or narrow-banded.

Relay K1 allows the subreceiver to share the main receiver's RF source, or use its auxiliary RF input. This means that two receiving antennas could be used. But it's also possible to route a single receiving antenna to both the RX ANT IN and AUX RF jacks using a "Y" adapter. This would allow the subreceiver to use the antenna connected to RX ANT IN even if the main receiver were using ANT 1. No external splitter is required because only one of the receivers will be connected to the receiving antenna at a time.

Not shown are the four other jacks on the KXV3 module: RX ANT OUT, XVTR IN and OUT, and IF OUT (buffered I.F. output). The RX ANT OUT jack can be used with RX ANT IN to "patch in" an external band-pass or low-pass filter for the main RF path (shared with the subreceiver with K1 in the position shown).

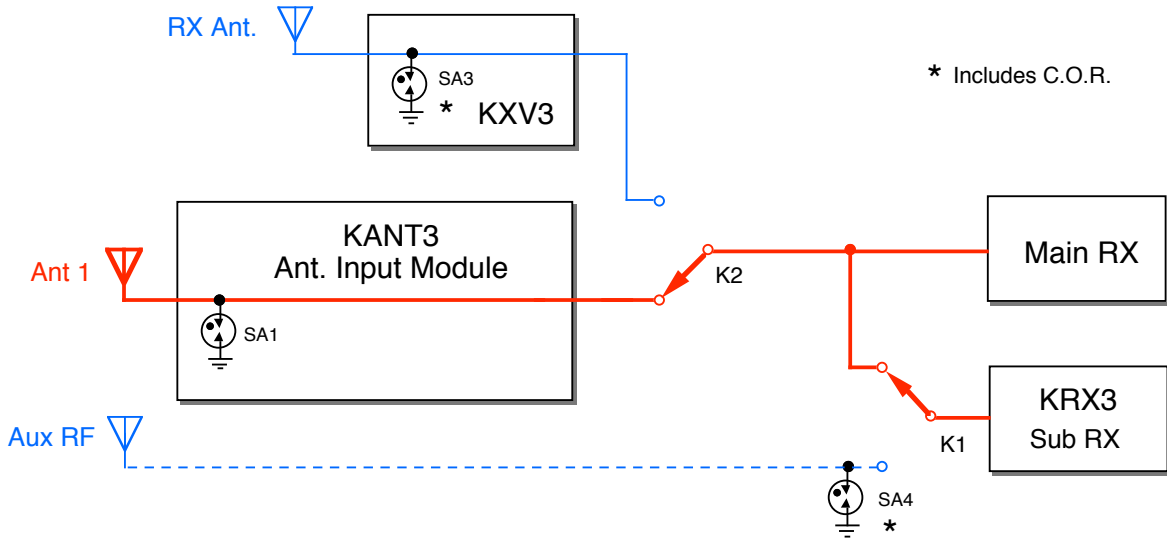

Figure 2. Main/Sub Receiver Routing with KXV3 Installed

ANT 2 (KAT3)

The KAT3 internal ATU provides a second SO239 antenna jack (ANT 2). As shown in Figure 3, relay K3 routes either ANT 1 or ANT 2 to the main RF path. The antenna *not* routed to the main path (the *non-transmit* antenna) is available for the subreceiver. Relay K1 selects either the main RX path (shown here), or the non-transmit antenna.

The subreceiver's auxiliary input can optionally be routed to the AUX RF connector rather than to the non-transmit KAT3 antenna. The subreceiver would be able to use either the main path (transmit antenna) or AUX RF.

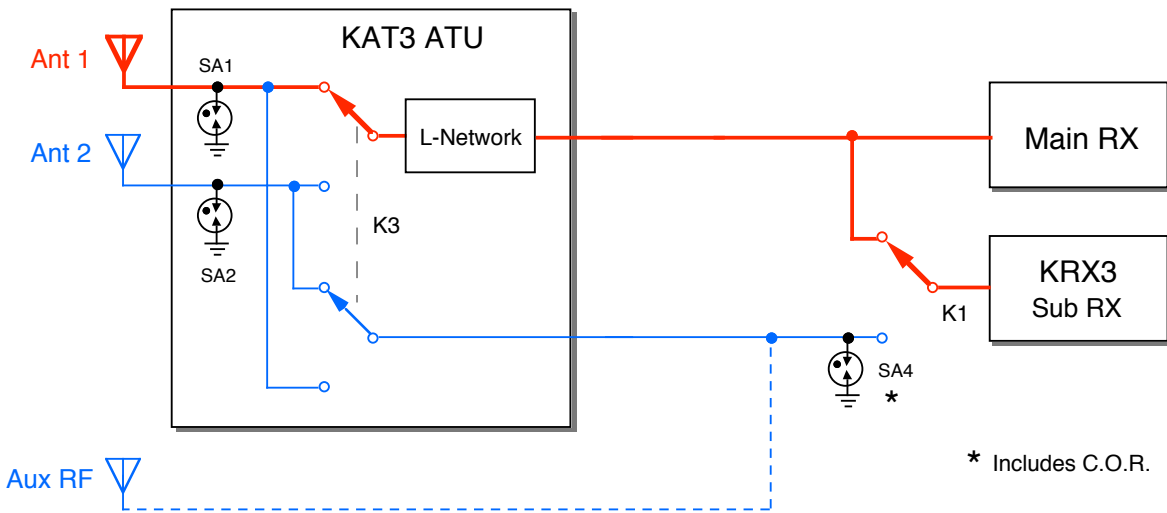

Figure 3. Main/Sub Receiver Routing with KAT3 Installed

Figure 4 shows the antenna routing possibilities with both the KAT3 and KXV3 installed. The main receiver can use ANT 1, ANT 2, or RX ANT IN. The subreceiver, when turned on, can either share the main receiver's RF source or use its auxiliary input, meaning either the non-transmit KAT3 antenna or AUX RF. In the latter case, you could use two receive-only antennas – one for each receiver – while still using either ANT 1 or ANT 2 for transmit.

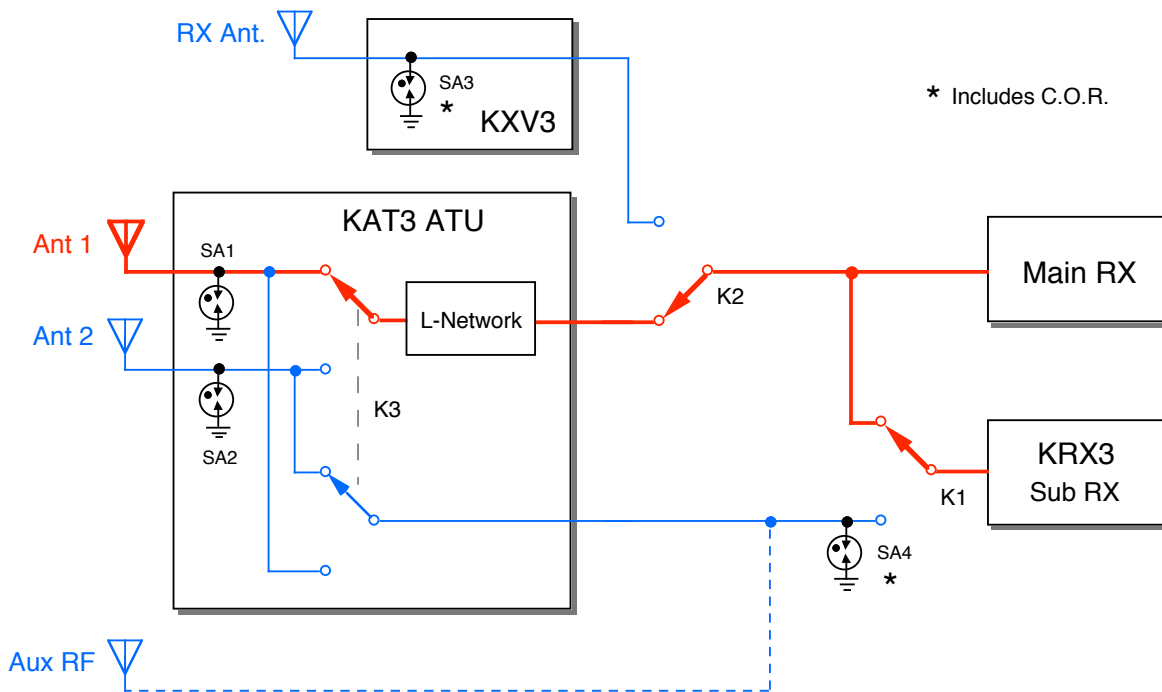

Figure 4. Main/Sub Receiver Routing with KXV3 and KAT3

Selecting The Main Receiver Antenna

Tap **ANT** to select **ANT 1** or **ANT 2**. To select the receive antenna (RX ANT IN), tap **RX ANT**. The **RX** icon will turn on. You'll still be able to tap **ANT** to select **ANT 1** or **ANT 2** for use with the transmitter.

Selecting The Subreceiver Antenna

Normally, the antenna icons (**RX** and **ANT 1 - 2**) show which antenna is in use by the main receiver. To see which antenna is selected for the subreceiver, hold **BSET**. **BSET** will appear on the VFO A display.

While in **BSET** mode, the **RX ANT** switch is used to select the subreceiver's auxiliary RF input (**RX** icon on). If the **RX** icon is off, the subreceiver is sharing the main receiver's RF source. In either case, the **ANT 1 - 2** icons will show which KAT3 antenna is available for use by the subreceiver. If sharing, it will be the same antenna in use by the main receiver. If not sharing, it will be the non-transmit antenna.

Tapping **ANT** while in **BSET** will switch antennas on the KAT3, affecting which antenna is in use by both the main and subreceivers, as well as the transmitter. When you exit **BSET**, look at the antenna icons to verify that any expected change in the settings for the main receiver has occurred.